

# Target Bench (HIL)

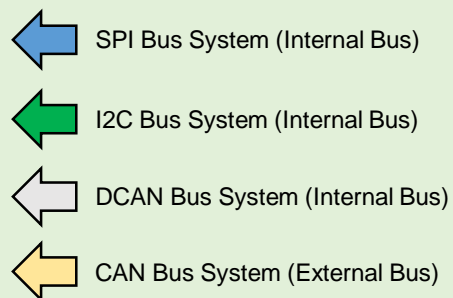
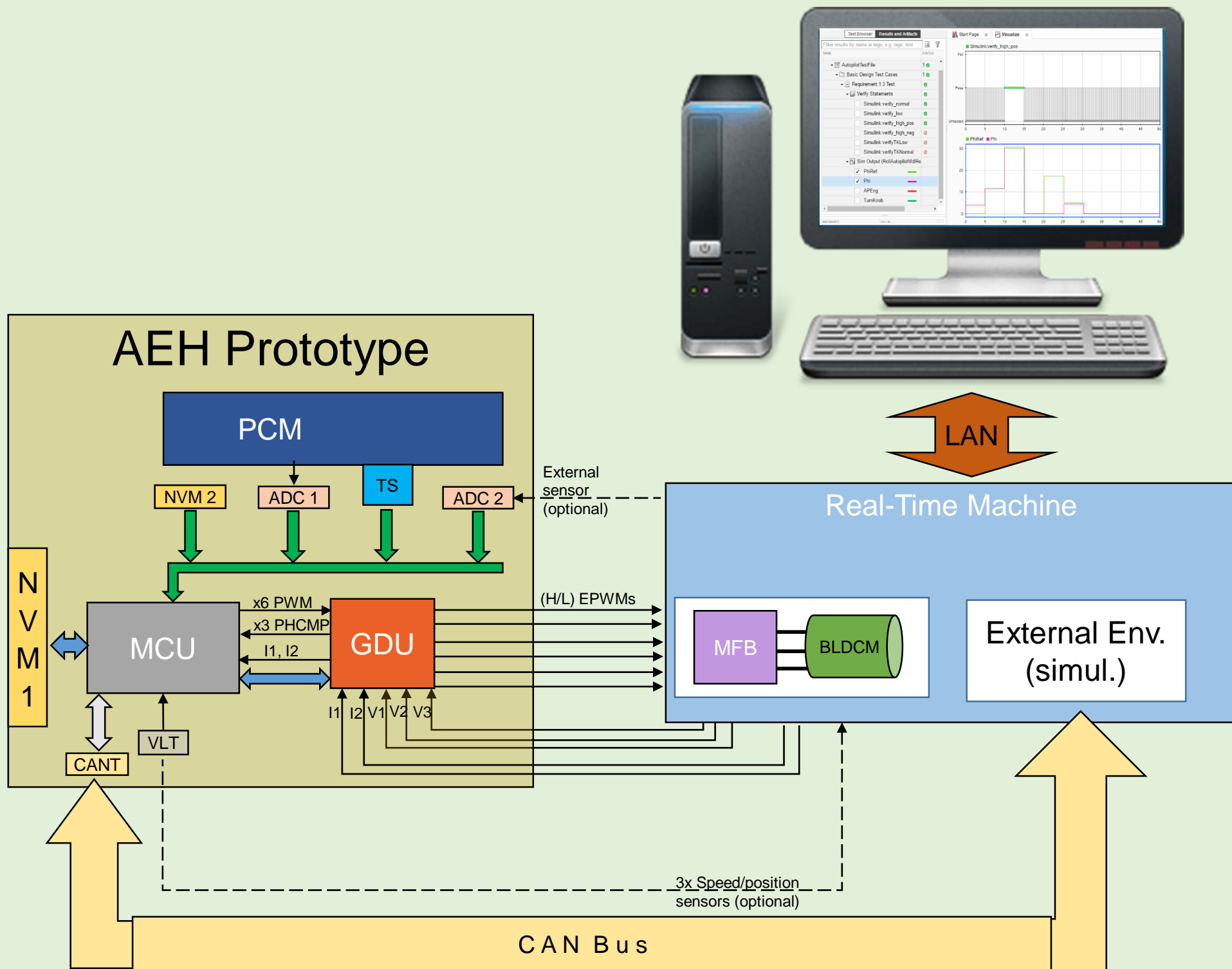

ADC	Analog-Digital Converter
BLDCM	(Brushless DC) Motor
CANT	CAN-bus Transceiver
EFM	External Filtering Module
EPWM	Enhanced PWM
GDU	Gate Driver Unit
MCU	Microcontroller Unit
MFB	Mosfet Bridge
NVM	Non-Volatile Memory
PCM	Power Conditioning Module
PHCMP	Phase Comparator
PWM	Pulse Width Modulation
TS	Temperature Sensor