

*safety in test > safety in flight*

TESTFUCHS

# Test Equipment for Airbus A400M



[WWW.TEST-FUCHS.COM](http://WWW.TEST-FUCHS.COM)

---

Hydraulic Servicing Trolley >HST21DSKA-M1<	AJA29009200
Hydraulic Servicing Trolley >HST21ESKA-M1<	AJA29009208
RAT GTT Hydraulic Service >RTI400M<	AJE24244895000
Oxygen and Nitrogen Trolley >ONT1-M1<	AJA35009207
Engine Fire Extinguishing System Test Tool >EFESTT1<	
Mobile Air Conditioner Diesel Motor Powered >BKG8D<	
Calibration Transfer Standard >CTS1<	
Electrical module for A400M cargo door and ramp operation >MCDRI<	

---

Bleeding Tool Set >BTS1<	
Hydraulic - Simulation For IRON BIRD A400M >GFTB400M<	
Engine Driven Hydraulics Pumps Loading System >HPLS400<	
Mobile hydraulic testing unit >MHPA400M<	
Particle measuring system for A400M >PMA400M<	
Test system for Cargo Hold and Tunable Vibration Absorber System >TS-CH-TVAS1<	
Test system for the Door Ramp Actuation System >TS-DRAS1<	
VFG Cooling system >VCS400<	
Electrical And Hydraulical Test Equipment Tact 5 >EHP400T5<	

---

Cable test equipment >KPG4<	
Servicing trolley for Flaps and Thrust Reversers >SFTR1<	
Water Separator System >WSS1-20SK<	
Bonding Tester	
A400M Tools	

## Hydraulic Servicing Trolley

> **HST21DSKA-M1** < (Diesel Driven)

> **HST21ESKA-M1** < (Electrically Driven)



> HST21DSKA-M1 or HST21ESKA-M1 is part of the HST21 "family" and is designed for the use on the following aircraft types:

- AIRBUS A400M

> It can be adapted for other aircraft types as well.

> Infinitely variable pressure and flow regulation

> Air separation by vacuum tank

> Infinitely variable pressure and flow regulation

> Operation and indication on one Touch-screen-panel

> Service friendly by large maintenance flaps with gas springs

> RAT-Test for 5000psi with additional test device >RTI400M< possible

## GENERAL INFORMATION

- > Automatic tow bar brake
- > Cable reel and motor operated hose drums (separate button for each drum)
- > Operating elements are well arranged, user friendly and practical;  
Manual or automatic usage for calibration
- > Operation possible in open (usage of the HST-reservoir) and closed circuit (usage of the aircraft reservoir)
- > Increased hydraulics output by interconnection of both autonomous circuits to one big circuit
- > Filling and draining the aircraft reservoir
- > Automatic self test of the equipment during start

## DIFFERENCE BETWEEN HST21DSKA-M1 and HST21ESKA-M1

- > HST21DSKA-M1: drive of the hydraulic system by a central diesel motor, 152kW, 1,500rpm,
- > HST21ESKA-M1: drive of the hydraulic system by a commercial electrical motor with 132kW,  
The required electrical nominal current supply is 3/N/PE AC 50Hz with a mains fuse of 250A by means of a 15m long connecting cable.
- > Sound insulation max. 80.0dB(A), permanent noise emission max. 94.5dB(A) in 1m (3.3ft)  
distance to the HST21DSKA-M1
- > Sound insulation max. 75.5dB(A), permanent noise emission max. 78.9dB(A) in 1m (3.3ft)  
distance to the HST21ESKA-M1

TECHNICAL DATA

> **Hydraulic parameters:**

Compressed air: 8bar (116psi)  
200l/min (52.8USgal/min)

Main tank: Tank volume 270 liters

> **Electrical supply (requirements):**

Mains connection: 3/PE AC 50Hz 400V,  
60Hz 380V

Nominal current: 250A

Performance: 173kVA

> **Dimensions and weight:**

Length: 4.950mm (16.2ft)

Width: 1.900mm (6.2ft)

Height: 1.930mm (6.3ft)

Weight: 5.300kg (11.685lb)

> **Measurements:**

Flow: 1 to 250l/min (0.3 to 66USgal/min)  
(2 off each) 0.02 to 4l/min (0.005 to 1.06USgal/min)  
±0.5% of full scale

Pressure: 0 to 400bar (0 to 5800psi)  
(2 off each) 0 to 16bar (0 to 230psi)  
±0.5% of full scale

Temperature: -40 to +100°C (-40 to +212°F)  
(2 off) ±1°C of full scale

> **Operating conditions:**

Operating temperature: -32 to +55°C (-25.6 to +131°F)

Storage temperature: -40 to +71°C (-40 to +160°F)

Height: up to 3.048m (10,000ft)  
over MSL

Rel. air humidity: 10 to 95% (non-condensing)

Setup: up to "Fire Standard E10,  
Hangar's Zone 2"





## RAT GTT Hydraulic Service

### >RTI400M<



Developed as an interface between  
HST21DSKA / HST21ESKA and RAT-GTT.

- > Highest safety level with bus connection via cable to release 5,000psi
- > Couplings for direct connection to RAT-GTT and HST21DSKA / HST21ESKA
- > Safety circuit in RTI400M for off-load run-out of the RAT-GTT in case of a failure on HST21DSKA / HST21ESKA

## GENERAL

- > Power supply by HST21DSKA / HST21ESKA
- > On-off valve for selective pressure release of 5,000psi only to RAT-GTT
- > Simple and compact setup on a mobile steel lift truck, easy manoeuvre to the respective application site
- > Fixture to store the test cable not in use

## TECHNICAL DATA

### > **Pressure supply:**

Pressure supply by HST21DSKA / HST21ESKA  
max. 5,000psi

### > **Dimensions and weight:**

Length: approx. 650mm (approx. 25.6in)  
Width: approx. 600mm (approx. 23.6in)  
Height: approx. 1,300mm (approx. 51.2in)  
Weight: approx. 50kg (approx. 110.2lb)

### > **Operating conditions:**

Operating temperature: -32°C to +55°C  
(-25.6°F to +131°F)

Storage temperature: -35°C to +55°C  
(-31°F to +131°F)

Installation height: up to 1,000m MSL

Air humidity: up to 95%  
(non-condensing)

# Oxygen And Nitrogen Trolley

## >ONT1-M1<

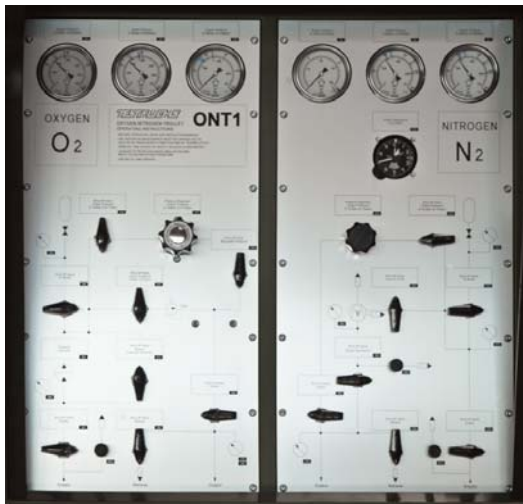

Regulable oxygen supply for the aircraft

- to test and pressure test the oxygen system with nitrogen
- for leakage and performance tests on the AIRBUS A400M according to ATA Chapter 35
- to fill portable breath oxygen bottles on the AIRBUS A400M

It is possible to adapt this trolley for other aircraft types.

- > The vacuum pump is driven by nitrogen, thus making it independent of electrical or compressed air supply
- > Three oxygen bottles and one nitrogen bottle are provided
- > Freely interconnectable flowmeter and ultrasonic leakage detector for leakage search in portable setup
- > Temperature monitored filling of the portable oxygen bottle possible
- > The equipment can operate in an unsheltered environment



## GENERAL INFORMATION

- > A compressed air driven pressure intensifier can be used when refilling the bottles from a source with lower pressure
- > If required bottles can be removed separately
- > Output is effected via a 10m stainless steel hose mounted on a spring loaded drum
- > Earthing cable with copper clamp approx. 15m with spring loaded drum
- > Simple maintenance by means of a GRP cover fitted with a gas filled strut
- > The parking brakes on the front axle are operated by lowering or lifting to the vertical position
- > The operating panel is covered when not in use by a shutter

## TECHNICAL DATA

<p>&gt; <b>Oxygen circuit:</b></p> <p>Input pressure: 50 - 300bar (725 - 4,350psi)</p> <p>Output pressure: 0 - 150bar (0 - 2,176psi) 192bar (2,785psi)</p> <p>Storage capacity: 150l at 300bar (3 bottles per 50 l) (40USgal at 4,350psi)</p> <p>Safety valve: 310bar (4,500psi)</p>	<p>&gt; <b>Vacuum circuit:</b></p> <p>Working pressure: 6bar (87psi) (Nitrogen)</p> <p>Vacuum: 0.5 - 1bar abs. (7.3 - 14.5psi) 0 - 22.000ft</p> <p>Suction capacity: 33.6NI/min (0.9USgal/min)</p>
<p>&gt; <b>Nitrogen circuit:</b></p> <p>Input pressure : 50 - 200bar (725 - 2,900psi)</p> <p>Output pressure: 0 - 10,5bar (0 - 152psi)</p> <p>Storage capacity: 50l at 200bar (1 bottle) (13USgal at 2,900psi)</p> <p>Safety valve : 210bar (3,046psi)</p>	<p>&gt; <b>Measurements:</b></p> <p>Pressure: 0 - 400bar ± 4bar (0 - 5,800psi ± 58psi)</p> <p>0 - 250bar ± 2.5bar (0 - 3,626psi ± 36psi)</p> <p>0 - 14bar ± 0.1bar (0 - 203psi ± 1.5psi)</p> <p>Altimeter: 0 - 22,000ft ± 100ft</p> <p>Flow: 0.2 - 5lpm ± 0.2lpm (0.05 - 1.3USgpm ± 0.05USgpm)</p>
<p>&gt; <b>Pressure intensifier (for filling the unit):</b></p> <p>Input pressure : max. 300bar (4,350psi)</p> <p>Output pressure: 300bar (4,350psi)</p> <p>Working pressure: 6 - 10bar (87 - 145psi) (Compressed air)</p>	<p>&gt; <b>Dimensions and weight (tow bar vertical):</b></p> <p>Length: 2,890mm (9.5ft)</p> <p>Width: 1,190mm (3.9ft)</p> <p>Height: 1,420mm (4.7ft)</p> <p>Weight: 950kg (2,094lb)</p>
<p>Operating temperature: -30 to +50°C</p>	<p>Maximum towing speed is 25km/h (15mph)</p>

## OPTIONS

Many options are possible for adaption, e.g. adaption to other aircraft types, to different touch-screens etc.

Technical data are subject to change!

# Engine Fire Extinguishing System Test Tool

## >EFESTT1<



The equipment is developed to test leakage of the A400M pipework running to the discharge nozzles of the Engine Fire Extinguishing System.

It is possible to adapt the equipment to other aircraft types.

- > The equipment is supplied by an external nitrogen bottle
- > Control elements are neatly arranged and situated on the control panel inside the case
- > Two test modes are available for system tests:
  - Leak Test
  - Clog Test

## GENERAL INFORMATION

- > Outlet pressure can be read at the pressure gauge
- > The equipment is integrated in a solid transport case
- > A wide range of accessories, e.g. adaptations, hoses and dummy caps is available to seal the discharge nozzles of the aircraft during operation
- > The tests can be carried out during the regular “base maintenance“

## TECHNICAL DATA

### > Pneumatic supply (requirements):

External nitrogen supply:      max. 30bar  
 (435.1psi)

### > Pneumatic parameters:

Nitrogen output:              max. 24bar (348.1psi)

- Leak Test:      23bar (333.6psi)  
 - Clog Test:      2bar (29.0psi)

### > Operating conditions:

Altitude:                              max. 1,000m (3,281ft) MSL  
 Operating temperature:      -15 to +40°C (5 to 95°F)  
 Storage temperature:      -40 to +70°C (-40 to +158°F)  
 Rel. humidity:                      5 to 95% (non-condensing)

### > Dimensions and weight:

Width:                              approx. 570mm (22.5in)  
 Height:                              approx. 300mm (11.8in)  
 Depth:                              approx. 450mm (17.7in)

Weight:                              approx. 18kg (40lb)



## OPTIONS

Various options are available to meet our customers' requirements.

>EFESTT1<

Technical data are subject to change!

# Mobile Air Conditioner Diesel Motor Powered

## >BKG8D<



The test stand is developed to air condition (cooling and heating) the AIRBUS A400M while on ground

It is possible to adapt this test stand for other aircraft types

- > The fitted touch panel enables easy and user friendly control of the equipment
- > The screw compressor requires little maintenance
- > Continuous operation of the equipment is possible
- > The device is provided with a high performance cooling capacity
- > Pipes conveying air are thermally insulated
- > The fitted diesel generator set operates in accordance with the EU emission standard IIIA

## GENERAL INFORMATION

- > Doors and coverings can be opened easily thus enabling easy access for maintenance
- > The turntable steering ensures high maneuverability of the unit
- > The parking brake is fitted at the rear axle
- > Fork lift access points and tie down points are provided for transportation

## TECHNICAL DATA

<p>&gt; <b>Hydraulic / pneumatic parameters:</b></p> <p><u>Adjustable air volume:</u> 3000 or 6000m<sup>3</sup>/h (105,944 or 211,888ft<sup>3</sup>/h) (can be adjusted variably)</p> <p><u>Supply pressure:</u> max. 10kPa (1.45psi)</p> <p><u>Adjustable outlet temperature:</u> 5 to 50°C (41 to 122°F)</p> <p><u>Nominal cooling capacity:</u> 150kW</p> <p><u>Refrigerant:</u> R134a</p> <p><u>Max. heating capacity:</u> 75kW (temperature is limited to 70°C)</p>	<p>&gt; <b>Medium:</b></p> <p>Ambient air</p>
<p>&gt; <b>Diesel generator set:</b></p> <p>Tank capacity: 400l</p> <p>Diesel consumption at 75% engine load: appr. 38.5lph</p>	<p>&gt; <b>Conditions of service:</b></p> <p>Ambient temperature: -25 to +49°C (-13 to 120.2°F)</p> <p>Storage temperature: -35 to +60°C (-31 to 159.8°F)</p> <p>Altitude: up to 1,000m above MSL (3,280ft)</p> <p>Rel. air humidity: 10 to 100% (non-condensing)</p> <p>Towing speed: max. 10km/h (6.2mph)</p>
	<p>&gt; <b>Dimensions and weight:</b></p> <p>Length: approx. 6,600mm (252.0in), (tow bar stowed in vertical position)</p> <p>Width: approx. 2,400mm (94.5in)</p> <p>Height: approx. 2,500mm (98.4in)</p> <p>Weight: approx. 6,400kg (14.330lb)</p>

## OPTIONS

Various options are available to meet our customers' requirements, e.g.: Appointed as power generator for other devices, operation without diesel generator with external power supply

# Calibration Transfer Standard

## >CTS1<



For autocalibration of the “Hydraulic Servicing Trolley <HST21D> and <HST21E>.

Calibration of pressure and flow with comparison (reference) - sensors.

Adjustment of flow set-values via flow control valves.

- > Instructions via monitor of the <HST21D/E> to carry out all necessary activities (e.g. identification, installation, printing)
- > Controlling and recording of measuring data via PLC installed in the <CTS1> and connected as “Master” with the control- and measuring computer of the <HST21D/E>
- > Temperature sensors to compensate different medium temperatures between <HST21D/E> and <CTS1>
- > Self test before starting the calibration to find malfunctions of the test device <CTS1> or connection faults (e.g. operating voltage, line break, pressure, flow)



## TECHNICAL DATA

<p><b>&gt; Operating conditions:</b></p> <p>Ambient temperature +18°C to +28°C</p> <p>Humidity of air: 0-90 % rel. humidity (non-condensing)</p> <p>Pressure: 800 to 1200 mbar A (800 mbar = 1950 m NN)</p> <p>Operating temperature (Fluid): +40°C to +65°C (70°C)</p> <p>Electrical supply: by &lt;HST21D&gt;</p> <p>Hydraulic supply by &lt;HST21D&gt;</p>	<p><b>&gt; Measurements:</b></p> <p>Flow: 0.02-4lpm accuracy: 0.25 % f.s.</p> <p>Flow: 4-210lpm accuracy: 0.25 % f.s.</p> <p>Pressure: 0-16bar accuracy: 0.125 % f.s.</p> <p>Pressure: 0-400 bar accuracy: 0.125 % f.s.</p> <p>Temperature : 0-50°C (Ambience) accuracy: +/-1 °C.</p> <p>Temperature : 40-65 °C (Fluid) accuracy: +/- 0.25°C.</p>
	<p><b>&gt; Dimensions and weight:</b></p> <p>Depth: 600mm</p> <p>Width: 600mm</p> <p>Height: 1.200mm</p> <p>Weight: approx. 235kg</p>

# Electrical module for A400M cargo door and ramp operation

## >MCDR1<



The Test Set <MCDR1> EADS CASA Part No: PrO000523620100A is designed to manually test and operate the A400M Cargo Door and Loading Ramp.

- > The following functions can be carried out on the test set using the respective switches or buttons:
  - Activating the hydraulic supply
  - Releasing and locking the cargo door drive
  - Opening and closing the cargo door
  - Releasing and locking the ramp drive
  - Extending and retracting the ramp
  
- > The following operational status of the cargo door and ramp are indicated on the control panel:
  - Hydraulic pressure indication
  - Ramp pressure 1
  - Ramp pressure 2
  - Ramp pressure 3

## GENERAL INFORMATION

- > The Test Set <MCDR1> is equipped with Cable Harness to connect to the various UUT connections and to provide electrical power to the Test Set.
- > EADS CASA P/N: PRO0005236201A

## TECHNICAL DATA

### > Electric Supply (Requirements):

- Connection: 1/N/PE AC 50Hz 230V
- Power: 0,29kVA
- Nominal current: 1A
- Connection:: via cable with EURO earth contact shockproof plug

### > Dimensions and Weight:

- Length: approx 250mm (approx 0.8ft)
- Width: approx 180mm (approx 0.6ft)
- Height: approx 85mm (approx 0.3ft)
- Weight: approx 6.2kg (approx 13.7lb)

### > Electric Parameters:

- Power consumption per solenoid:  
28VDC / 700mA
- Max. power consumption:  
6 Solenoids (4.2ADC) at the same time



## OPTIONS

A wide range of options is available to fulfil our customers requirements.  
e.g.: Adaption for different aircraft types, etc.

## Bleeding Tool Set

### >BTS1<



This rig is developed to bleed hydraulic components at stations 15 and 35 of the Airbus A400M in the final assembly line.

It can be used for other aircraft types when suitable adapted, in accordance with ATA Chapter 29.

- > The rig can be used for any application using HYJET Type V
- > The flow in the pressure and return lines can be regulated by throttle valves
- > Two pressure gauges indicate the pressure in the pressure and return line
- > A sight glass in the return line enables HYJET Type V to be observed

## GENERAL INFORMATION

- > Storage space is provided to enable various accessories e.g. test hoses and connecting hoses, adapters etc. to be stored.
- > A drip tray enables leaked medium to be captured, which can be drained via a drain cock
- > The rig is fitted with lifting rings and fork lift points and thus can be transported by crane, forklift truck or moved on its castors for short distances
- > The use of stainless steel and anodised control consoles make the rig resistant to the test medium and cleaning fluids
- > All components are permanently identified with their part number



Control Console with throttle valves, pressure gauges and the sight glass

## TECHNICAL DATA

<p>&gt; <b>Dimensions and weight:</b></p> <p>Length: 1.325mm (4,3ft)                  Width: 950mm (3,1ft)                  Height: 1.040mm (3,4ft)                  Weight: 330kg (728lb)</p>	<p>&gt; <b>Measurement range:</b></p> <p>Pressure: 0 - 400bar (0 to 5800 psi)                  (inside the pressure line)</p> <p>Pressure: 0 - 40bar (0 to 580 psi)                  (inside the return line)</p>
<p>&gt; <b>Medium:</b></p> <p>HYJET Type V</p>	

Technical data are subject to change!

# Hydraulic - Simulation For IRON BIRD A400M

## >GTFB400M<

(GROUPES DE TRANSFERT DE FLUIDE DU BANC GENERAL A400M)

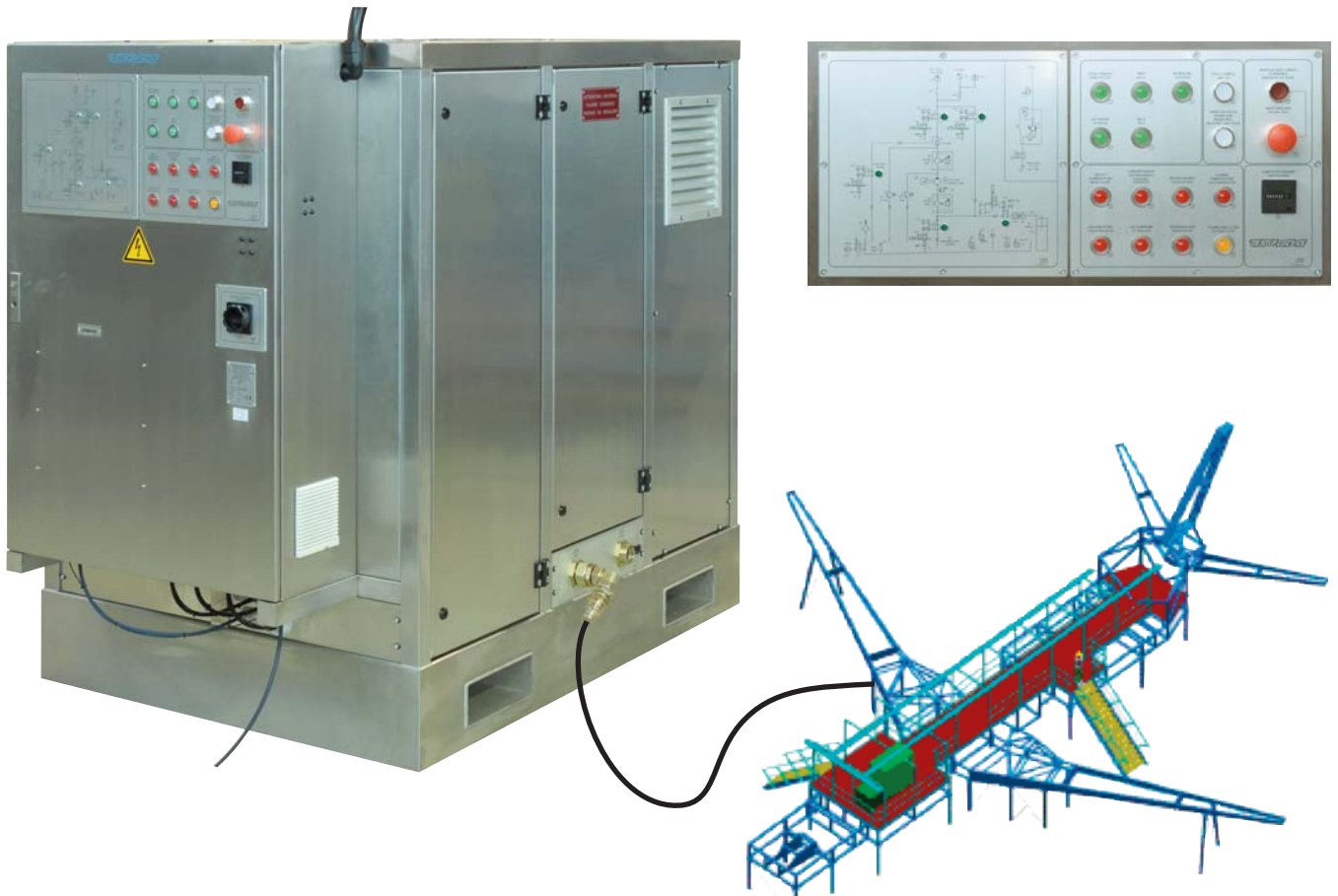

Originally designed for the IRON BIRD A400M.

Can be adapted for other A/C-types.

- > For controlled filling/draining of hydraulic systems of the A400M
- > Easy manual operation
- > Interface for external control and measuring data acquisition
- > Stainless steel construction for medium Skydrol



## GENERAL FUNCTIONAL DESCRIPTION

- > The <GTFB400M> serves for simulation of consumers in closed hydraulic systems of the IRON BIRD A400M. These are among others steering setting of the front wheel, the front gear, the main gear, the doors and ramps, the brake system, the safety brake unit and the lifting and kneeling at loading of the gear.
- > The integration in the system is done via connection of a hydraulic hose and via control line to the main computer.

## MISCELLANEOUS

- > Control via external interface possible

## TECHNICAL DATA

<p>&gt; <b>Hydraulic parameter:</b></p> <p>Main reservoir: Capacity: 350l (92.5gal)                      Pressure: 0 to 7bar (0 to 101psi)                      Flow: 10 to 70lpm (2.6 to 18.5gpm)                      1. Filter degree: 10µ Filter                      2. Filter degree: 3µ Filter</p>	<p>&gt; <b>Measurements:</b></p> <p>Temperature: 0 to 100°C ±0.5K                      (0 to 212°F)                      Pressure: 0 to 16bar ±1%                      (0 to 232psi)                      Flow: 1 to 80lpm ±1%</p>
<p>&gt; <b>Mains supply:</b></p> <p>3/N/PE AC 50Hz 400V                      Nominal current: 9.5A</p>	<p>&gt; <b>Dimensions and weight:</b></p> <p>Length: 1,980mm (6.5ft)                      Width: 1,150mm (3.8ft)                      Height: 1,610mm (6.3ft)                      Weight: 1,000kg (2,205lb)</p>
<p>&gt; <b>Medium:</b></p> <p>Skydrol 5</p>	

## OPTIONS

A wide range of options is available to fulfil our customers' requirements.  
 e.g.: Adaption for different aircraft types, etc.

# Engine Driven Hydraulics Pumps Loading System

## >HPLS400<



The loading system is developed for use with the AIRBUS A400M engine (TP400-D6) test stand.

It is possible to adapt this loading system for other aircraft engines.

- > The equipment supplies the engine driven pump with hydraulic oil.
- > The pump can be loaded by controlling the flow.
- > Cooling of hydraulic oil is ensured.
- > The return pressure of hydraulic oil is controlled.

## MISCELLANEOUS

- > The system is operated and controlled using an external control unit.
- > The temperature is controlled by the engine test stand.
- > The test bench has an ergonomic and compact design.
- > The test bench can be transported by fork lift truck or by crane.

## TECHNICAL DATA

<p>&gt; <b>Electrical connected loads:</b></p> <p><u>Power supply:</u> 3/N/PE AC 50Hz 400V Nominal current: 25A</p> <p><u>“Control unit supply”:</u> 2/DC/24V Nominal current: 1.4A</p>	<p>&gt; <b>Control range:</b></p> <p>Temperature: 0 to 100°C (32 to 212°F) (required values can be set manually or from the engine test stand)</p> <p>Flow: 10 to 250lpm (2.6 to 66USgpm) (required values can be set manually or from the engine test stand)</p>
<p>&gt; <b>Hydraulical parameters:</b></p> <p>Input pressure: max. 250bar (3,626psi) Flow: max. 250lpm (66USgpm) Main reservoir: 60l (15.9USgal) Filtration level: 3µ filter</p>	<p>&gt; <b>Measurement range:</b></p> <p>Pressure: 0 to 400bar ±0.5% (0 to 5,802psi)</p> <p>Flow: 10 to 250lpm ±1% (2.6 to 66USgpm)</p> <p>Temperature: 0 to 100°C ±1.5°C (32 to 212°F) (±2.7°F)</p>
<p>&gt; <b>Compressed air supply:</b></p> <p>Pressure: 4.5 to 10bar (65.3 to 145psi) Flow: 220lpm (58USgpm) Nominal diameter: 3/8"</p>	<p>&gt; <b>Dimensions and weight:</b></p> <p><u>“TEST BENCH &lt;HPLS400+1&gt;”:</u> Width: 1,970mm (6.5ft) Depth: 1,130mm (3.7ft) Height: 1,280mm (4.2ft) Weight: 830kg (1,830lb)</p> <p><u>“CONTROL UNIT &lt;HPLS400+2&gt;”:</u> Width: 250mm (0.8ft) Depth: 330mm (1.1ft) Height: 125mm (0.4ft) Weight: 4.8kg (10.6lb)</p>
<p>&gt; <b>Cooling water supply:</b></p> <p>Pressure: 3 to 16bar (43.5 to 232psi) Flow: 20lpm (5.3USgpm) Nominal diameter: 1 1/4"</p>	
<p>&gt; <b>Medium:</b></p> <p>SKYDROL Type IV and V</p>	

Technical data are subject to change!

## Mobile hydraulic testing unit

### >MHPA400M<

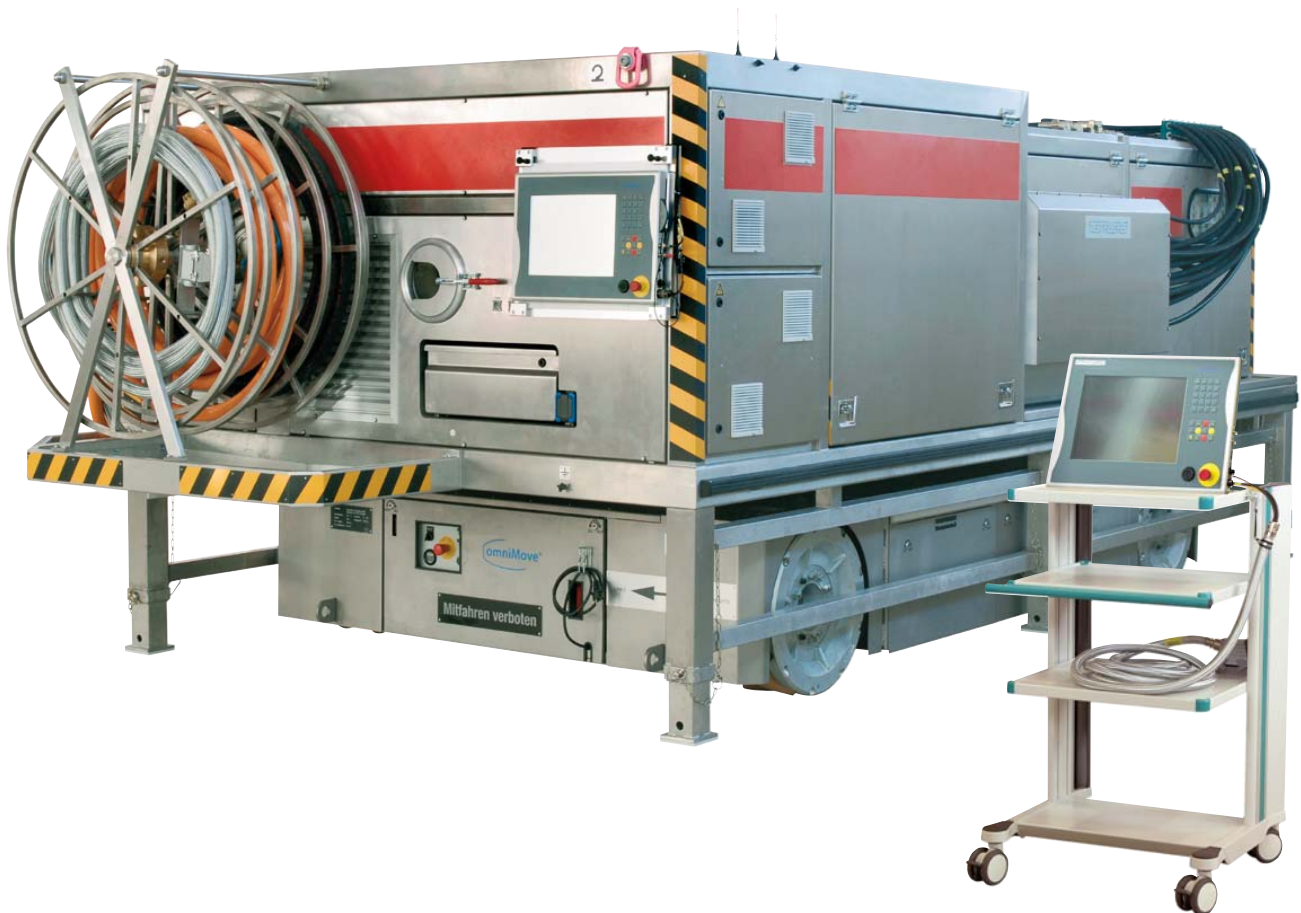

This equipment is developed to carry out all hydraulic testing requirements for the A400M Fuselage Hydraulic Circuits.

It is possible to adapt this equipment for other aircraft types.

- > Tests:
  - Pressure test using Exxon HYJET V
  - Flushing
  - Particle measurement
  - Purging using compressed air
- > Fully automatic test sequences
- > Outflow air is filtered to a high standard using three filtration levels
- > Particle measurement is carried out using 15 particle measurement trolleys, which can be positioned close to the measuring points
- > The equipment is easy to use due to the self-propelled main trolley and compact test trolleys

## MISCELLANEOUS

- > A modem is fitted to allow maintenance/updates to the software for remote maintenance
- > Calibration is carried out autonomously by the software
- > A radio controlled remote control panel
- > Ergonomic and compact design of the complete test equipment

## TECHNICAL DATA

<p>&gt; <b>Hydraulic parameters:</b></p> <p><u>Circulating/supply circuit:</u>                  Pressure: max. 15 bar (218 psi)                  Supply rate: 0 - 180 lpm (0 - 48 USgpm)</p> <p><u>Filling/testing circuit:</u>                  Pressure: max. 240 bar (3481 psi)                  Supply rate: 0 - 140 lpm (0 - 37 USgpm)</p> <p><u>High pressure circuit:</u>                  Pressure: 0 - 250 bar (0 - 3626 psi)                  Flow: 0 - 100 lpm (0 - 26 USgpm)</p> <p><u>Low pressure circuit:</u>                  Pressure: 0 - 100 bar (0 - 1450 psi)                  Flow: 0 - 100 lpm (0 - 26 USgpm)</p> <p><u>Suction circuit:</u>                  Pressure: 0 - 16 bar (0 - 232 psi)                  Flow: 0 - 100 lpm (0 - 26 USgpm)</p>	<p>&gt; <b>Electric parameters:</b></p> <p><u>Unit component "Pressure station":</u>                  3/N/PE AC 50 Hz 400 V                  Power: 145.5 kVA                  Nominal current: 210 A                  Back-up fuse: 250 A</p> <p><u>Trolleys:</u>                  1/N/PE AC 50 Hz 230 V                  Earthed sockets                  Back-up fuse: 16 A</p>
<p>&gt; <b>Pneumatic parameters:</b></p> <p><u>Unit component "Pressure station":</u>                  5 - 10 bar (72.5 - 145 psi)</p> <p><u>Trolley supply:</u>                  5 - 10 bar (72.5 - 145 psi)</p>	<p>&gt; <b>Measurement range:</b></p> <p>Pressure: 0 - 6 bar (87 psi)                  (27 meas.) 0 - 40 bar (580 psi)                  0 - 100 bar (1450 psi)                  0 - 250 bar (3626 psi)                  ± 0.5 % o.r.</p> <p>Temperature: 0 - 100 °C (0 - 212 °F)                  (24 meas.) ± 1 °C</p> <p>Flow: 0 - 20 lpm (5.3 USgpm)                  (16 meas.) 0 - 100 lpm (26.4 USgpm)                  ± 0.5 % o.r.</p> <p>Humidity: 0 - 100 % rel. humidity                  ± 5 % rel. humidity</p>
<p>&gt; <b>Medium:</b></p> <p>Exxon HVJET V</p>	

## DIMENSIONS AND WEIGHTS

### > Unit component „MAIN TROLLEY“:

Length:	4500 mm	(14.8 ft)
Width:	2490 mm	(8.2 ft)
Height:	1950 mm	(6.4 ft)
Weight:	6800 kg	(14990 lb)

### > Unit component „TEST TROLLEY 1>“:

Length:	900 mm	(3.0 ft)
Width:	960 mm	(3.1 ft)
Height:	960 mm	(3.1 ft)
Weight:	240 kg	(529 lb)

### > Unit component „PARTICLE MEASURING TROLLEY 1“:

Length:	1600 mm	(5.2 ft)
Width:	980 mm	(3.2 ft)
Height:	1080 mm	(3.5 ft)
Weight:	415 kg	(915 lb)

### > Unit component „PRESSURE STATION“:

Compressor:

Length:	1250 mm	(4.1 ft)
Width:	700 mm	(2.3 ft)
Height:	900 mm	(3.0 ft)
Weight:	280 kg	(617 lb)

Pressure reservoir:

Diameter:	1300 mm	(4.3 ft)
Height:	2400 mm	(7.9 ft)
Weight:	1100 kg	(2425 lb)

Switch cabinet:

Length:	1200 mm	(3.9 ft)
Width:	500 mm	(1.6 ft)
Height:	2200 mm	(7.2 ft)
Weight:	270 kg	(595 lb)

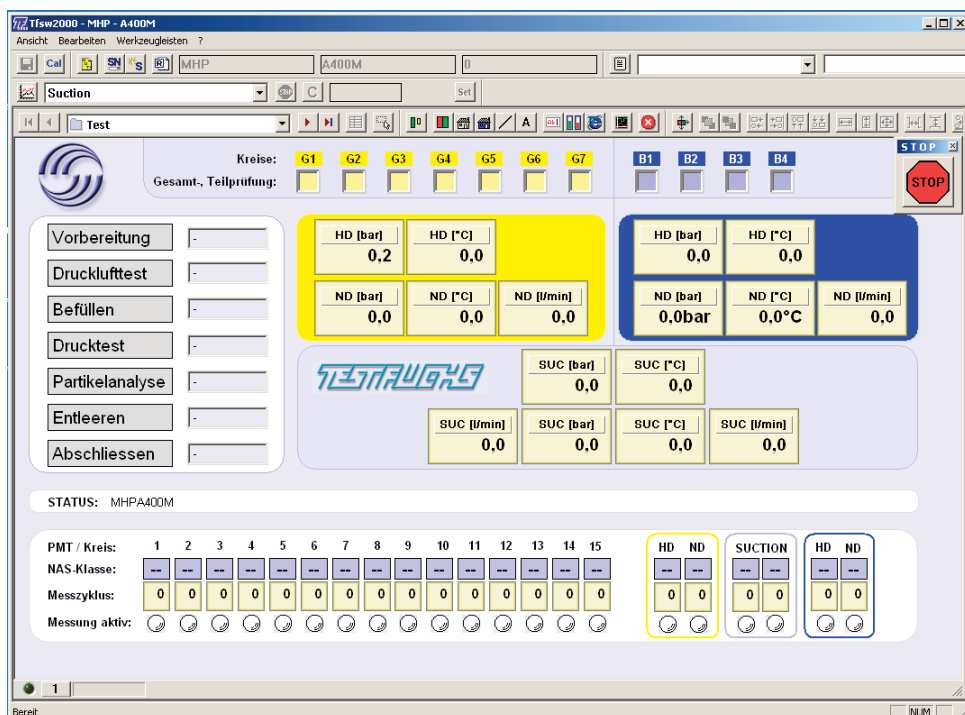

User interface





Pressure reservoir



Electrostatic cleaner



Switch cabinet



Compressor



15 particle measuring trolleys



6 test trolleys

## OPTIONS

Many options are possible for adaption, e.g. adaption to other aircraft types, to different touch-screens etc.

Technical data are subject to change!

## Particle measuring system for A400M

### >PMA400M<



This equipment is developed to test the hydraulic pipe work in the fuselage (section 13-18) of the A400M. Tests are carried out i.a.w. ATA Chapter 29 and 27.

It is possible to adapt this equipment for other aircraft types.

- > Tests:
  - Pressure test using air
  - Filling the system with Exxon Hyjet V
  - Hydraulic pressurization test
  - Hydraulic particle analysis
- > Tests can be carried out partially or fully automatic
- > The equipment is mobile to ensure that it can be positioned where required

## GENERAL INFORMATION

- > A modem is fitted to the equipment, enabling the software to be maintained at the factory
- > Calibration is carried out autonomously by the software
- > A SIMATIC touch panel is used to control the equipment
- > A cable drum and motor driven hose drums are mounted
- > The equipment can be transported by fork lift truck

## TECHNICAL DATA

<p>&gt; <b>Hydraulic parameters:</b></p> <p>Flow:           max. 100lpm (26.4USgpm)                   at 85bar (1.233psi)</p> <p>                  max. 50lpm (13.2USgpm)                   at 250bar (2.626psi)</p>	<p>&gt; <b>Measurement range:</b></p> <p>Pressure:       0 - 250bar ± 0.5% (4-off)           (0 - 3626psi ± 0.5%)                   0 - 16bar ± 0.5%                   (0 - 232psi ± 0.5%)</p> <p>Temperature:   0 - 100°C ± 1°C (3-off)           (32 - 212°F ± 1.8°F)</p> <p>Flow:            0 - 100l/min ± 0.5%                   (0 - 26.4USgpm ± 0.5%)</p> <p>Particle measurement is carried out i.a.w. AS4059 or NAS1638</p>
<p>&gt; <b>Pneumatic parameters:</b></p> <p>Input:           min. 6bar (87psi)                   max. 10bar (145psi)</p>	<p>&gt; <b>Dimensions and weight:</b></p> <p>Length:          4.980mm     (14.8ft) Width:           1.500mm     (5.2ft) Height:          1.600mm     (5.6ft) Weight:          3.000kg     (7.716lb)</p>
<p>&gt; <b>Medium:</b></p> <p>Exxon Hyjet V</p>	
<p>&gt; <b>Electrical parameters:</b></p> <p>3/N/PE AC 50Hz 400V Nominal current:   60A Power:            41.5kVA Back-up fuse:      63A</p>	

## OPTIONS

Many options are possible for adaption, e.g. adaption to other aircraft types, to different touch-screens etc.

Technical data are subject to change!

# Test System for Cargo Hold and Tunable Vibration Absorber System

## >TS-CH-TVAS1<



Designed as electrical power supply and in order to perform CAN-bus simulation for the Tunable Vibration Absorber System of AIRBUS A400M.

In addition this test system serves to perform functional tests on different consumers in the cargo hold of AIRBUS A400M.

Can be adapted for other aircraft types.

- > Ergonomic, compact design
- > Integrated, hinged touch panel
- > Integrated, extendable drawer for keyboard and mouse
- > Connection via CEE plug (16A) with 10m cable

## MISCELLANEOUS

- > This test bench serves to perform functional tests on different consumers in the **cargo hold (CH)** and for testing electric installation of **Tunable Vibration Absorbers (TVAS)**.
- > Functions of the following systems are tested - inside the **cargo hold (CH)**:
  - lockings and guideways of cargo hold floors (roller restraint system)
  - crane inside the cargo hold
  - miscellaneous consumers (miscellaneous equipment)
- > By reduction of structure vibrations the **Tunable Vibration Absorbers System (TVAS)** reduces the noise level (caused by propellers) inside the cargo hold.

## TECHNICAL DATA

### > Electrical connected loads:

Main supply: 3/N/PE AC 50Hz 400V  
 Power: 10.2kVA  
 Nominal current: 15A  
 Back-up fuse: 16A

### > Dimensions and weight:

Width: 700mm (2.3ft)  
 Depth: 800mm (2.6ft)  
 Height: 2050mm (6.7ft)  
 Weight: 300kg (660lb)

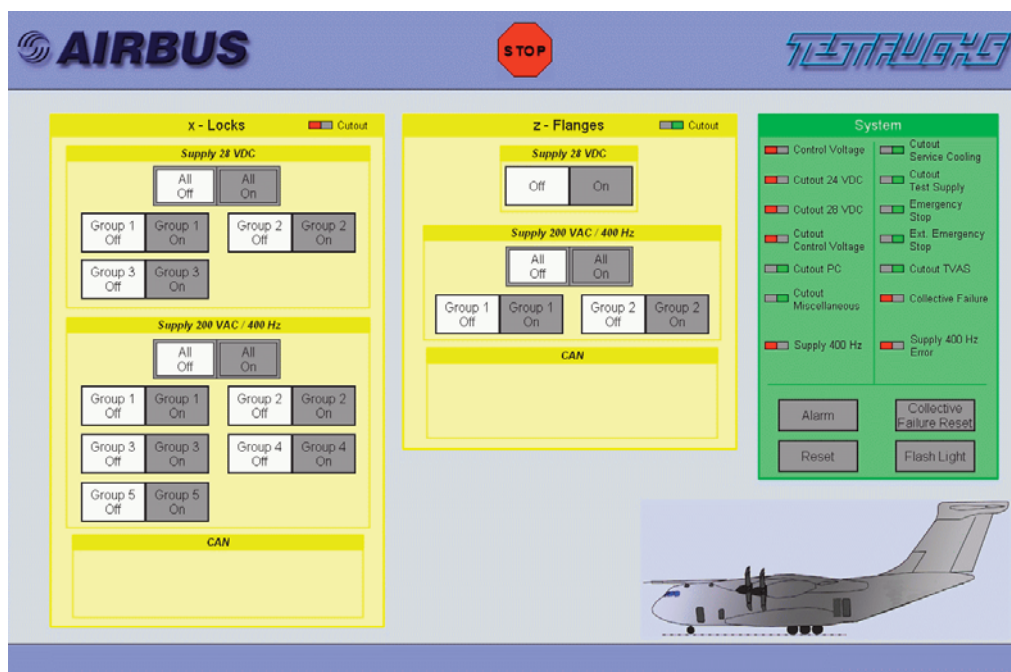

User interface

By using individual buttons, 28VDC resp. 200VAC/400Hz commands are transferred to hydraulic consumers in the **Cargo Hold (CH)** and to the **Tunable Vibration Absorbers System (TVAS)** of A400M.

## OPTIONS

A wide range of options is available to fulfil our customers' requirements. e.g.: Adaption for other aircraft types, different cable length, etc.

Technical data are subject to change!



# Test System for the Door Ramp Actuation System >TS-DRAS1<



Designed as electrical valve control for the Door Ramp Actuation System (DRAS) of AIRBUS A400M.

Can be adapted for other aircraft types.

- > Ergonomic, compact design
- > Integrated, hinged touch panel
- > Integrated, extendable drawer for keyboard and mouse
- > Connection via CEE plug (16 A) with 10 m cable



## MISCELLANEOUS

- > The test bench serves to perform functional tests at the Door Ramp Actuation System (DRAS).
- > A400M DRAS is used for moving the ramp (latching/locking), the gate of the cargo hold (down-latching, down-locking, up-latching), for moving stabilizer struts, ramp toes and air deflectors.
- > Ramp and gate at the rear end of the aircraft allow access to the cargo hold. Access is required for passengers or for loading/unloading of cargo.
- > Stabilizer struts prevent the aircraft from tilting during loading/unloading.
- > Ramp toes are designed as bypass during loading/unloading of vehicles and passengers. Furthermore for loading/unloading of pallets and platforms from floors of trucks.
- > The air deflector opens a guard door for parachutists.

## TECHNICAL DATA

### > Electrical connected loads:

Mains connection:	3/N/PE AC 50 Hz 400 V
Power:	10.2 kVA
Nominal current:	6.6 A
Back-up fuse:	16 A

### > Dimensions and weight:

Width:	600 mm	(2.0 ft)
Depth:	700 mm	(2.3 ft)
Height:	1250 mm	(4.1 ft)
Weight:	150 kg	(330 lb)

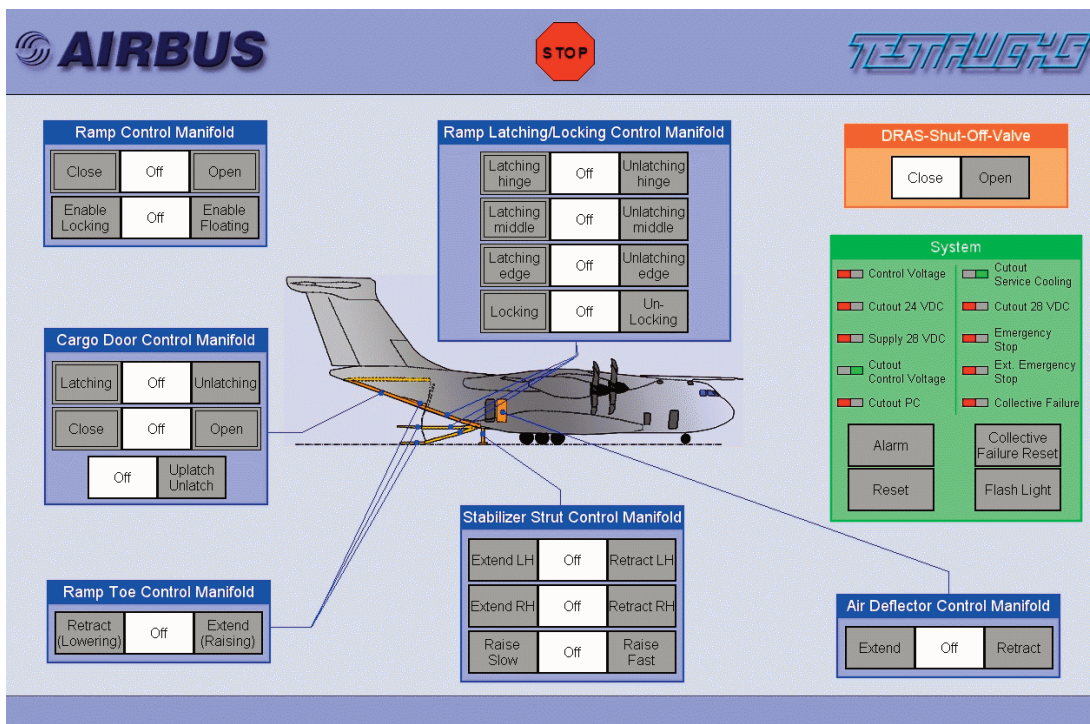

User interface

By using individual buttons, 28 VDC commands are transferred to hydraulic consumers of A400M to test individual settings.

## OPTIONS

A wide range of options is available to fulfil our customers' requirements. e.g.: Adaption for different aircraft types, different cable length, etc.

Technical data are subject to change!

## VFG Cooling system

### >VCS400<



The cooling system is developed for use with the AIRBUS A400M engine (TP400-D6) test stand and is designed to cool lube oil of the Variable Frequency Generator.

It is possible to adapt this system for other aircraft types.

- > The return oil temperature is measured
- > The return oil temperature is controlled by adjusting the cooling water flow
- > A cooler bypass is provided to enable low temperature tests of oil (down to -40°C)

## MISCELLANEOUS

- > The system is operated and controlled using an external control unit
- > The equipment is ergonomic and compact
- > The test bench can be moved by fork lift truck or crane

## TECHNICAL DATA

<p>&gt; <b>Hydraulic parameters:</b></p> <p>Input pressure: max. 20 bar (290 psi) Flow: max. 25 lpm (6.6 US gpm)</p>	<p>&gt; <b>Control range:</b></p> <p>Temperature: 0 - 100 °C (32 - 212 °F) (Internal or external values can be set manually)</p>
<p>&gt; <b>Compressed air supply:</b></p> <p>Pressure: 4 - 10 bar (58 - 145 psi) Flow: 220 lpm (58 US gpm) Nominal diameter: 3/8"</p>	<p>&gt; <b>Measurement range:</b></p> <p>Pressure: 0 - 25 bar ± 0.5 % (0 - 363 psi)</p> <p>Temperature: 0 - 100 °C ± 1.5 °C (32 - 212 °F) (± 2.7 °F)</p>
<p>&gt; <b>Cooling water supply:</b></p> <p>Pressure: 0 - 16 bar (0 - 232 psi) Flow: max. 20 lpm (5.3 US gpm) Nominal diameter: 3/4"</p>	<p>&gt; <b>Dimensions and weight:</b></p> <p><u>TEST BENCH:</u></p> <p>Width: 1430 mm (4.7 ft) Depth: 590 mm (1.9 ft) Height: 880 mm (2.9 ft) Weight: 270 kg (595 lb)</p>
<p>&gt; <b>Medium:</b></p> <p>MIL-L-23699, MIL-L-7808</p>	<p><u>CONTROL UNIT:</u></p> <p>Width: 250 mm (0.8 ft) Depth: 330 mm (1.1 ft) Height: 125 mm (0.4 ft) Weight: 4.5 kg (9.9 lb)</p>
<p>&gt; <b>Electrical parameters:</b></p> <p><u>Power supply:</u> 1/N/PE AC 50 Hz 230 V Nominal current: approx. 3 A</p> <p><u>"Control unit" supply:</u> 2/DC/24 V Nominal current: approx. 2 A</p>	

## OPTIONS

A wide range of options is available to fulfil our customers' requirements.  
e.g.: Adaption for different aircraft types, etc.

Technical data are subject to change!

# Electrical And Hydraulical Test Equipment Tact 5 >EHP400T5<



Figure of a similar equipment

Developed for providing an electrical and hydraulic supply for testing the electrical and hydraulic systems of the tail fin of the A400M

> The following tests can be carried out on the vertical fin:

- Bonding test
- Loop resistance measurement
- Antenna test
- Angular movements of the rudder
- Pressure test by compressed air or hydraulic oil
- Filling, draining and purging of the hydraulic system
- Particle measurement

## GENERAL INFORMATION

- > Fully automatic test sequence ensures significant time saving
- > All castors, cables and hoses in the power unit are resistant to Skydrol
- > Controlled shutdown is carried out when errors or failures occur
- > Good accessibility is ensured for maintenance and service
- > Test results can be saved in test reports formatted by the user
- > Calibration is carried out by software
- > All measurements are shown on the monitor as well as warning and error messages

## TECHNICAL DATA

<p>&gt; <b>Hydraulic parameters:</b></p> <p>Main tank: Volume: 300l Leakage warning, safety valve, cleaning access, temperature monitoring</p> <p>Medium: SKYDROL LD4 SKYDROL 5</p> <p>Circulating and supply circuits: Internal gear pump Output 145l/min</p> <p>High pressure circuits: Three separate circuits Axial piston pump Output: 5 to 75l/min at max. 350bar</p> <p>Return circuits: Pressure transducer 0 to 100bar</p>	<p>&gt; <b>Electrical supply (requirements):</b></p> <p>Mains supply: 3/N/PE AC 50Hz 400V Nominal current: 225A Power: max. 156kVA Back-up fuse: 250A</p> <hr/> <p>&gt; <b>Pneumatical supply (requirements):</b></p> <p>Pressure: 8bar</p> <hr/> <p>&gt; <b>Dimensions and weight:</b></p> <p>Power unit: Width: approx. 5170mm (17ft) Depth: approx. 2150mm (7.1ft) Height: approx. 2250mm (7.4ft)</p> <p>Rack no.1: Width: approx. 610mm (2ft) Depth: approx. 640mm (2.1ft) Height: approx. 1730mm (5.68ft)</p>
---	--

## TECHNICAL DATA

### > Measurement range:

#### Temperature sensors:

(9-off):	0 to 100°C (32 to 212°F) ±1K (1.8°F) absolute
(1-off):	-20 to +80°C (-4 to 176°F) ±1K (1.8°F) absolute

#### Pressure sensors:

(2-off):	0 to 10bar (0 to 145psi) ±0.5% m.v.
(3-off):	0 to 100bar (0 to 1450psi) ±0.5% m.v.
(4-off):	0 to 500bar (0 to 7251psi) ±0.5% m.v.
(1-off):	1 to 500bar (15 to 7251psi) ±0.5% m.v.
(1-off):	800 to 1.200mbar (11.6 to 17.4psi) ±0.5% m.v.

#### Flowmeters:

(3-off)	0 to 80l/min (0 to 21gpm) ±1% o.f.s.
---------	---

#### Angular measurement:

(1-off)	0 to 360l° ±0.02° absolute
---------	-------------------------------

#### Humidity:

(1-off)	0 to 100% ±5% o.f.s.
---------	-------------------------

m.v. .... measurement value

o.f.s. .... of full scale

## OPTIONS

A wide range of options is available to fulfil our customers' requirements.  
e.g.: Adaption for different aircraft types, etc.



## Cable test equipment

### >KPG4<



The cable test equipment is developed for testing installed cable looms in the A400M.

It is possible to adapt the cable tester for use on other aircraft types very easily thus reducing lead time to a minimum.

- > The test equipment is for rapid testing from connector to connector (end to end test).
- > The testing time is reduced to one minute only in comparison to the complex manual cable testing method.
- > Insulation, electric strength and continuity tests can be carried out.
- > There is a wide-range of adapter cables for connecting the test equipment to various cable looms.  
Additional adapters can be produced for use with the test equipment as required.

## RANGE OF APPLICATION

- > Cable loom installed in the A400M Fuselage
- > Cable looms in general
- > Individual cables

## GENERAL INFORMATION

- > The control unit is produced by CK Technologies and contains stimuli and measuring circuits, the required relay boards and connector sockets.
- > Operation of the equipment is carried out using a Tablet PC which together with its docking station and carrying harness can be stowed in the test equipment when not in use.
- > The test program instructs the user as to which adapter cable is to be attached to the cable under test.
- > A test program is provided for each cable thus enabling every cable in the cable loom to be tested individually.
- > Due to the compact design and mobility, the test equipment can be used in every situation.
- > The adapter cables have identification labels and are stowed in storage cabinets.

## TECHNICAL DATA

<p>&gt; <b>Technical data of CKT control unit:</b></p> <p>Test points: 200</p> <p>Continuity test: 0.05 to 50 V 100 µA to 2A</p> <p>Resistance testing: 2 wire 0.1 to 500 kOhm</p> <p>Insulation test rate: 0.25 to 1300 VDC 5 mA limited up to 1000 MOhm</p> <p>Proof voltage: 3 to 750 VAC 50 Hz</p> <p>Continuity test rate: 3000 Tests/minute</p> <p>Insulation test rate: 1000 Tests/minute</p>	<p>&gt; <b>Electrical supply:</b></p> <p>Mains connection: 1/N/PE AC 50 Hz 230 V Nominal capacity: 0.23 kVA Nominal current: 1 A</p> <p>&gt; <b>Dimensions and weight:</b></p> <p>Length: 850 mm (2.8 ft) (incl. cable holder)</p> <p>Depth: 1100 mm (3.6 ft) (incl. cable drum)</p> <p>Height: 1570 mm (5.2 ft) (incl. warning light)</p> <p>Weight: 160 kg (352.7 lb)</p>
--	---

## OPTIONS

A wide range of options is available to fulfil our customers' requirements.  
e.g.: Adaption for other aircraft types, different cable lengths, etc.

Technical data are subject to change!

## Servicing Trolley for Flaps and Thrust Reversers

### >SFTR1<



The equipment is developed to provide a controlled movement of Flap and Thrust Reverser Actuators during servicing and adjustment in accordance with the ATA chapter 29.

It is used in the civil aviation field for AIRBUS and BOEING aircraft.

It can be adapted for use on other aircraft types.

The equipment is fitted with:

- > An Axial Piston pump which enables the maximum flow of 15 l/min to be quickly achieved.
- > An Air Cooled Heat Exchanger is used for cooling of the hydraulic oil in the <SFTR1>.
- > Temperature is controlled by a cut off thermostat.
- > Simple manual regulation of maximum pressure and flow.
- > Needle valves for hose pressure relief.
- > Oil Level Float Switch to monitor oil level and to indicate a minimum oil level.

## GENERAL INFORMATION

- > A compact design ensures easy transportation and fixed and steerable castors are provided for manoeuvrability during use.
- > Stainless steel framework protects against Skydrol and corrosion.

## TECHNICAL DATA

<p>&gt; <b>Current supply:</b></p> <p>Power: approx. 7.5 kW                      Voltage: 3/N/PE AC 50 Hz 400 V                      Supply cable: 10 m long (33 ft)</p>	<p>&gt; <b>Measurement range:</b></p> <p>Pressure: 0 - 400 bar (0 - 5800 psi)                      ± 1 % o.f.s.</p>
<p>&gt; <b>Performance data:</b></p> <p>Pressure: max. 230 bar (3336 psi)                      Axial piston pump: max. 15 l/min at 230 bar (max. 4 USgpm at 3336 psi)                      Reservoir capacity: 140 l (37 USgal)</p>	<p>&gt; <b>Operation conditions:</b></p> <p>Ambient temperature: +5 to +35 °C (+41 to +95 °F)                      Storage temperature: 0 to +60 °C (+32 to +140 °F)                      Humidity: 10 - 95 % rel. humidity                      Altitude: up to 1000 m above SL (up to 3280 ft above SL)                      Protection class: IP55</p>
<p>&gt; <b>Medium:</b></p> <p>Skydrol 500 B4</p>	<p>&gt; <b>Dimensions and weight</b></p> <p>Length: 1000 mm (3.3 ft)                      Width: 900 mm (3.0 ft)                      Height: 1210 mm (4.0 ft)                      Weight: 300 kg (660 lb)</p>
<p>&gt; <b>Output hoses:</b></p> <p>2-off: each 6 m (19.7 ft)</p>	

## OPTIONS

A wide range of options is available to fulfil our customers' requirements.  
 e.g.: Adaption for different aircraft types, etc.

# Water Separator System >WSS1-20SK<



Reliable separation of water from the hydraulic medium.

Intended application for Skydrol.

- > Max. water content after separation: 40ppm
- > No deletion of medium additives
- > Leak oil free quick disconnect couplings
- > Automatic control
- > Frothing in the oil does not affect the fill level measurement
- > Robust construction with cover

## TECHNICAL DATA

### > **Hydraulic parameters:**

#### Input pressure:

max. 16bar (230psi)

#### Flow:

max. 20lpm (5.3USgpm)

#### Pressure-/vacuum tank:

Capacity: 48l (12.7USgal)

#### Heater in the tank:

8 x 750W

#### 2 filter steps:

6 $\mu$ , Coalescer-Filter

#### Vacuum pump:

Ex-proof, 0.37kW

Nominal suction capacity: 16m<sup>3</sup>/h (565ft<sup>3</sup>/h)

#### Heat exchanger:

4 x 10kW

#### Inlet pump:

Flow: max. 20lpm (5.3USgpm)

#### Outlet pump:

Flow: max. 23lpm (6.1USgpm)

#### Cooler in the vacuum line:

40W

Flow quantity: 0.09kg/s (0.2lb/s)

### > **Electrical supply:**

Mains connection: 3/N/PE AC 50Hz 415V

Nominal current: 16A

Power: 11kVA

### > **Measurement range:**

Temperature: 0 to 150°C  $\pm$ 0.2%  
(0 to 300°F)

Pressure: 0 to 1.6bar abs.  $\pm$ 1%  
(0 to 23psi abs.)

Load cell: 0 to 2kN  $\pm$ 0.5%  
(0 to 450lbf)

Humidity in oil: 0 to 100%  $\pm$ 0.25%

### > **Dimensions and weight:**

Width: 1,100mm (3.6ft)

Depth: 1,200mm (3.9ft)

Height: 1,410mm (4.6ft)

Weight: approx. 700kg (1,540lb)

## OPTIONS

A wide range of options is available to fulfil our customers' requirements.

## Bonding Tests

### Complex aircraft structures

- > can be struck by lightning
- > are exposed to high temperature differences
- > are exposed to external electromagnetic fields and electrostatic charging
- > have to be suitably treated to minimize or prevent damage
- > are liable to corrosion due to environmental variations

For your passengers' safety - NDT conductivity tests ensure structural and electrical integrity!



#### ENVIRONMENTAL CHALLENGES

In the age of digital **fly by wire** control systems it has become more important than ever to ensure flight safety by performing accurate regular inspections. The control system must work at all times.

Aircraft are exposed to a large number of environmental challenges: lightning strikes, electromagnetic fields (radar, wireless and television, cosmic radiation), bird strikes, storm, hail, rain, humidity, rapid extreme pressure and temperature changes which result in vibration and shock loading. All this has an adverse effect on aircraft life and performance.

#### ELECTROSTATIC CHARGES

Electrostatic charges are generally created by passing through clouds or dusty low level air (helicopters). To prevent unintentional electrical discharge between aircraft components, all parts including the antennas should be conductively connected to one another in order to prevent navigation and communication systems malfunction.

#### TEMPERATURE CHANGES

At ground level an aircraft generally experiences higher temperatures and humidities than when operating at high altitudes. A temperature drop of  $-50^{\circ}\text{C}$  is commonplace. Temperature and pressure differences cause **water condensation** which collects in seams, low points and also in the lower cargo areas, where it even freezes.



## LIGHTNING STRIKES

**Most aircraft are struck by lightning on average once a year!** The main points of impact are the aircraft nose, wing tips, engines, vertical and horizontal tail tips, and the landing gear.

Although an aircraft is similar to a Faraday cage, lightning strikes (**lightning current**) creates electromagnetic fields, which cause high voltages when they are coupled through openings into the wiring and equipment. This can have serious consequences such as power supply interruption, malfunction of the computers or total shut-down of certain equipment or systems. Composite structures can be damaged by lightning current flow via components like flaps, valves, joints, pipe connections or equipment connector plugs.

## CORROSION

**Corrosion** is created where salt, moisture or corrosive fluids like skydrol come in contact with connections and cables. The resulting oxides reduce the conductivity, thus increasing the conductive connector resistances. As a result, in case of system failure, this will mean non or slow operation of the safety circuit breaker which can even result in a fire. Corroded structural connections can lead to enormous damage when subjected to a lightning strike. Unfortunately, this form of corrosion is not always visible to the naked eye.

## AIRBUS CERTIFIED



## TEST-FUCHS Bonding Testers are certified on AIRBUS aircraft

### EASY TO USE

TEST-FUCHS has developed and launched practical test equipment to meet the stringent safety critical requirements of bonding testing. The TEST-FUCHS Bonding Test Systems have been certified by AIRBUS on the use of AIRBUS Aircraft and are deployed successfully worldwide.

Bonding Test Systems are used in aircraft production and in line maintenance. The equipment is very easy to use and battery operated. For automatic measurements the user can store test sequences.

- ▶ Tests are easily performed by a single operator.
- ▶ All instruments are battery operated and compact for easy use in difficult access points.
- ▶ It is not required to remove parts or loosen screw connections.

Types of test equipment:

- > **Bonding Tester**
- > **Loop Resistance Tester**
- > **Anti Static Paint Tester**

Quality for your electrical interconnections!

## PREVENT AND LIMIT DAMAGES

- ▶ All equipment and its wiring must be screened and grounded in order to protect the flight critical aircraft components and systems from damage. As the grounding of an aircraft cannot be performed in the normal way, the whole aircraft structure itself is used as ground.
- ▶ In addition special methods and materials are used during manufacture to prevent corrosion as far as possible. Critical areas are protected by using special sealing material and paint.
- ▶ The fuel tanks must have a redundant electrical bonding to ensure prevention of the possibility of an explosion if normal bonding fails i.e. failsafe.
- ▶ A continuous good electricity conductivity of the aircraft structure, especially of the outer skin, minimises or protects it from damage by lightning strikes or electrostatic discharges. Structures made of fiber composites together with associated equipment and wires are especially prone to damage.
- ▶ It is very important that junctions, screw connections, connectors, earthing cables, cable ducts, etc. are tested for conductivity, but they are often very difficult to access.
- ▶ By testing the resistance of screens, equipment, structural components etc. it is possible to detect compliance to regulations during manufacturing processes, or if the connections, despite ageing, meet the requirements.
- ▶ The performance of these measures in the manufacture and in service phases is normally subject to stringent quality control.

## CALIBRATION

TEST-FUCHS recommends yearly calibration of the test systems to safeguard the system specification compliance.

Calibration can be performed at the customer's premises or in one of the TEST-FUCHS locations close to you.



## FUNCTION OF BONDING TESTERS

All conductive aircraft components are electrically connected to one another. These connections must have a minimal electrical resistance to prevent damage in cases of lightning strike or residual current in the aircraft systems.

Test points are the screening, screw connections, earthing straps, and pipes including connections. A test

current (e.g. 10A) is fed into the measurement point. Based on the voltage drop the contact resistance is calculated.

TEST-FUCHS Bonding Testers are designed to perform accurate and easy resistance measurements, especially on extremely low impedance units under test (UUT).

## MEASURING PRINCIPLE

### Point to point measurement:

test point

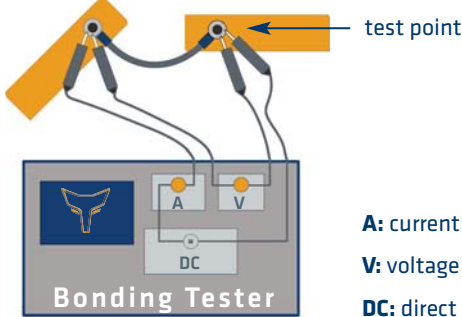

### Used Test Currents:

10A DC	normally
0 - 150A DC	for tests between wings and fuselage
0,1A DC	for sensitive UUTs

### Typical Connection Resistance:

1-100mΩ

### Operational Methods:

Bonding Testers use the so called four-wire system method (the KELVIN Method). Thus all the transition and cable resistances will be compensated to ensure that the test results are correct.

### Point to structure measurement:

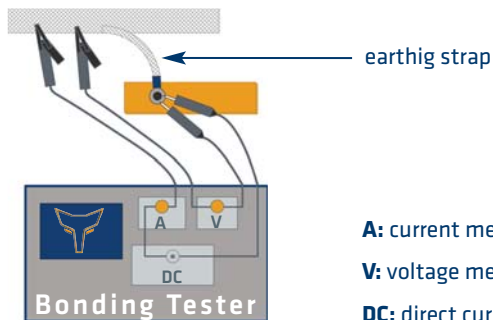

### Testing Times:

These are dependent on the type of bonding tester used.

### Return current measurement:

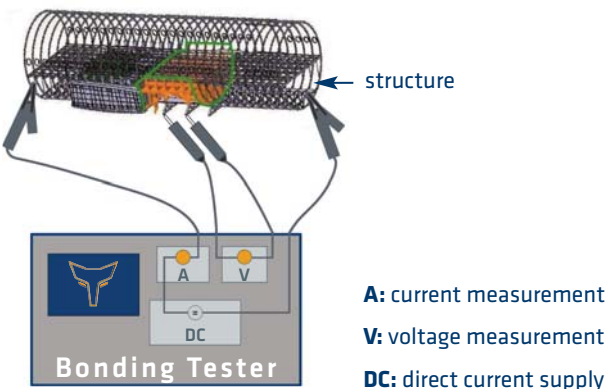

### Test Cables:

Individual test cables match any testing requirements. The customer chooses the appropriate length and end connections depending on the area of application.

There are A, B and AB cables. For a full four-wire measurement test either an A and a B cable or a combined AB cable are required.

## Bonding Tester >MVP10L-FS<

The Bonding Tester >MVP10L-FS< is used for fast and simple inspection of bonding connections. Test currents up to 10A are injected and the contact resistance is measured using the 4 wire test method.

- > Especially light and ergonomic design
- > Easy to read large display
- > Battery powered, rechargeable in situ or removed
- > Has a galvanically isolated interface for remote control or data exchange
- > Measurement current up to 10A with impulse current testing, automatic field switching and automatic polarity reversal
- > Automatic 4 wire identification
- > Can be hand carried, shoulder strap carried or operated placed on a suitable surface
- > Optional: usage of test sequences
- > Optional: adapter for bluetooth communication



<MVP10L-FS>  
(TEST-FUCHS item no. 151020009)

### TECHNICAL DATA

Power supply:	To charge the battery 1/N/PE AC 50Hz 230V ± 10%
Battery life:	up to 2000 measurements /charging
Battery:	2 x 7.2V Li-Ion
Charging time:	6 hours
Test current:	0.1A; 1A; 10A
Test voltage:	max. 8V
Pulse duration:	1sec, 3sec
Measurement mode:	2 or 4 wire measurement
Resolution:	from 1μΩ on

Accuracy:	± 0.2% of full scale and ± 0.2% of reading
Measurement range:	1mΩ, 10mΩ, 100mΩ, 600mΩ 1Ω, 6Ω, 10Ω, 60Ω, 600Ω, 6kΩ, 60kΩ 600kΩ for each measurement current
Measured value storage:	1000 measurements
Dimensions:	approx 25 x 13 x 16cm
Weight of equipment:	approx 2.8kg

### INCLUDED IN STANDARD SCOPE OF DELIVERY:



**Battery package**  
2 Batteries "S307149"  
(TEST-FUCHS item no. 106220138)



**Power supply unit incl. powercable**  
for battery charging „S306287“  
(TEST-FUCHS item no. 103070362)



**Shoulder strap „1472“**  
(TEST-FUCHS item no.  
106330923)



**Travel adapter („SKROSS PRO“)**  
(TEST-FUCHS item no.  
103206789)

### NOTE:

The required measurement cables are not included in the standard scope of delivery.

## Optional Accessories for Bonding Tester

### >MVP10L-FS<

#### Transport case "EXPLORER" (TEST-FUCHS item no. 107101335)

Very robust, stackable  
Lined with foam  
Storage compartment for:

- Bonding Tester <MVP10L-FS>
- Accessories
- Documentation

Dimensions: approx 58 x 44 x 16cm  
Weight: approx 5kg



#### Battery Package (2 Batteries „S307149” (TEST-FUCHS item no. 106220138)



Manufacturer: TEST-FUCHS  
Model: S307149  
Output voltage: 7.2V  
Power: 48Wh  
Intermediate charging possible (no memory effect)  
The equipment is fitted with 2 batteries

#### External Charger for 2 Batteries incl. Power Cable (TEST-FUCHS item no. 106220111)

Manufacturer: SWIT  
Model: SC-3602F  
Input: AC 100 - 240V; 50 / 60Hz  
Output: DC 7 - 8.4V; 1.8A  
Possible to charge 2 batteries at the same time





# Recommended Standard Measurement Cables for Bonding Tester >MVP10L-FS<

## NOTE:

For operation, at least one measurement cable A and one measurement cable B are required (otherwise, no closed circuit possible). The measurement cables are each delivered in a labeled cable bag.

### PKL668-9 (Measurement cable B) (TEST-FUCHS item no. 103240297)

The measurement cable is suitable for a fast bonding testing on stiff UUTs.

Type:	Test pin with spring mounted test prod
Max current:	max. 10A
Cable length:	3m
Test pin handle:	∅ 30 x 170mm
Test prod:	∅ 6 x 95mm



### PKL668-12 (Measurement cable A) (TEST-FUCHS item no. 103240298)

The measurement cable is suitable for the ground connection at the UUT. Each current and voltage poles are connected fixed with the structure.

Type:	Ground connection cable with 2 alligator clips
Max current:	max. 10A
Cable length:	5m
Safety tapper:	2 x XKK-1001



## FURTHER MEASUREMENT CABLES

### PKL668-2 (Measurement cable A+B) (TEST-FUCHS item no. 103240198)

The measurement cable is suitable for testing single screw connections. When placing the test prod on a measurement point, make sure all four contact points sit well. The measurement is carried out single-handed.

Type:	4 wire test pin for miniature UUTs (screw head)
Max current:	max. 10A
Cable length:	2.5m
Test pin handle:	∅ 16 x 70mm
Test prod:	∅ 8 x 12mm





**PKL668-3** (Measurement cable A+B) (TEST-FUCHS item no. 103240316)

This measurement cable is suitable for connection testing of pressed metallic screens. The measurement is carried out single-handed.

Type: 4 wire test prod, spring mounted (sharp / blunt)  
 Max current: max. 10A  
 Cable length: 2.5m  
 Test pin handle: 30 x 22 x 145mm  
 Test prod:  $\varnothing$  7 x 22mm

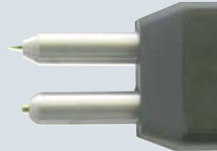

**PKL668-4** (Measurement cable A+B) (TEST-FUCHS item no. 103240296)

The measurement cable is suitable for general applications, where contact point to be measured is less than 12mm wide. The measurement is carried out single-handed.

Type: 4 wire test prod, spring mounted (sharp / sharp)  
 Max current: max. 10A  
 Cable length: 2.5m  
 Test pin handle: 30 x 22 x 145mm  
 Test prod:  $\varnothing$  7 x 22mm

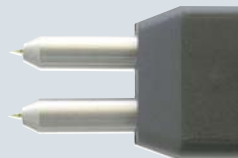

**PKL668-14** (Measurement cable A) (TEST-FUCHS item no. 103240310)

This measurement cable is suitable for a fast bonding testing on stiff UUTs.

Type: Test pin with spring mounted test prod  
 Max current: max. 10A  
 Cable length: 3m  
 Test pin handle:  $\varnothing$  30 x 170mm  
 Test prod:  $\varnothing$  6 x 95mm



**PKL668-45** (Measurement cable B) (TEST-FUCHS item no. 103240903)

This measuring cable is suitable for general applications. For the measurement, pressure peaks, clamps etc. can be connected etc. by means of normal straps with 4mm banana sockets of the measuring cable.

Type: Cable with banana sockets  
 Current load rating: max. 10A  
 Cable length: 5m



**FURTHER MODELS, SPECIAL MODELS OR OTHER CABLE LENGTHS ARE AVAILABLE ON REQUEST!**

## Bonding Tester

### > MVP10R-FS <

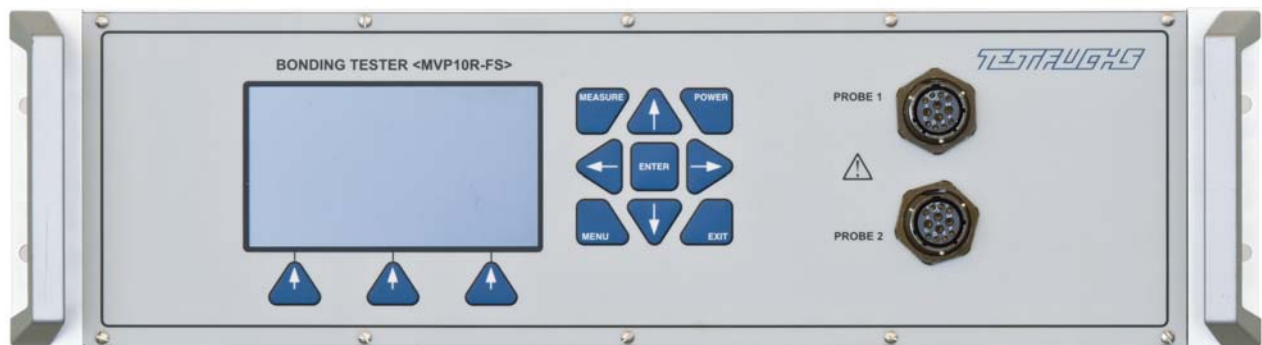

<MVP10R-FS>  
(TEST-FUCHS item no. 151020024)

Developed for fast and simple inspection of bonding.

Test currents of up to 10A are injected and the contact resistance is measured using the 4 wire test method.

The 19" rack design enables the tester to be incorporated into a special type test system.

- > Easy to read large display
- > Has a galvanically isolated interface for remote control or data exchange
- > Measurement current up to 10A with impulse current testing, automatic field switching and automatic polarity reversal
- > Automatic 4 wire identification
- > Two off connector sockets are fitted to the front and rear of the equipment

## TECHNICAL DATA

<p>&gt; <b>Electrical supply (requirements):</b></p> <p>Power connection: 1/N/PE AC 50Hz 230 Nominal current: 0.7A</p>	<p>&gt; <b>Measurement ranges:</b></p> <p>Measurement ranges: 1mΩ, 10mΩ, 100mΩ, 600mΩ, 1Ω, 6Ω, 10Ω, 60Ω, 600Ω, 6kΩ, 60kΩ, 600kΩ for each measurement current</p> <p>Accuracy: ± 0.2% of full scale and ± 0.2% of reading</p>
<p>&gt; <b>Performance:</b></p> <p>Test current: 0.1A; 1A; 10A Test voltage: max. 8V Pulse duration: 1sec, 3sec Meas. mode: 2 or 4 wire measurement Resolution: from 1μΩ on</p>	<p>&gt; <b>Dimensions and weight:</b></p> <p>Length: approx. 45cm Width: approx. 25cm Height: approx. 13cm Weight: approx. 5.4kg</p>

### INCLUDED IN STANDARD SCOPE OF DELIVERY:



**Power cable**  
(TEST-FUCHS item no. 103240028)

### OPTIONAL ACCESSORIES:



**19" Housing**  
(TEST-FUCHS item no. 107100466)

### NOTE:

The required measurement cables are not included in the standard scope of delivery. All accessories are in the brochures of the "BONDING TESTER <MVP10L-FS>".

## Test Equipment, Bonding Tester

### >PA-MVP11<



<PA-MVP11>  
(TEST-FUCHS item no. 150020029)

Developed for inspection of bondings using a test current of up to 200A continuous current.

Suitable for use with all common aircraft types.

- > Display and operating elements in an easy to use manner
- > Compact design
- > GRP - carrying case for safe transport

## TECHNICAL DATA

<p>&gt; <b>Electrical supply:</b></p> <p>Mains supply: 1/N/PE AC 50Hz 230V            Nominal current: 7A            Preliminary fuse: 16A</p>	<p>&gt; <b>Electrical parameters:</b></p> <p>Output current: 0 to 200A DC</p>
<p>&gt; <b>Measurement range:</b></p> <p><u>Current measurement:</u>            Digital amperemeter            Measurement range: 0 to 200A            Fault tolerance: Cl. 0.5</p> <p><u>Voltage drop measurement:</u>            Digital voltmeter            Measurement range: 0 to 2,000mV            Fault tolerance: Cl. 0.1</p>	<p>&gt; <b>Dimensions and weight:</b></p> <p>Width: approx. 63cm            Height: approx. 49cm            Depth: approx. 39cm            Weight: approx. 53kg (incl. test cable)</p>

## STANDARD ACCESSORIES

- > 2 measuring lines, each 10m (32.8ft) with alligator clip
- > 2 test lines, each 10m (32.8ft) for 200A
- > 1 power cable
- > 2 safety tapper
- > 5 cable bags

## OPTIONS

A wide range of options is available to fulfil our customers' requirements.

## Loop Resistance Testers

Electrical cables are screened at both ends and designed to form an electrical loop in which the current flows through the cable and back through the screen.

As a result, a magnetic field appears which is eliminated by the voltage build-up. If the loop resistance is kept at a minimum, then the maximum level of safety has been reached.

The loop resistance of non-electrical loops like pipes and flaps with multiple ground connections can also be measured in this way.

The loop resistance is tested accurately with easy to use equipment.

### MEASURING PRINCIPLE

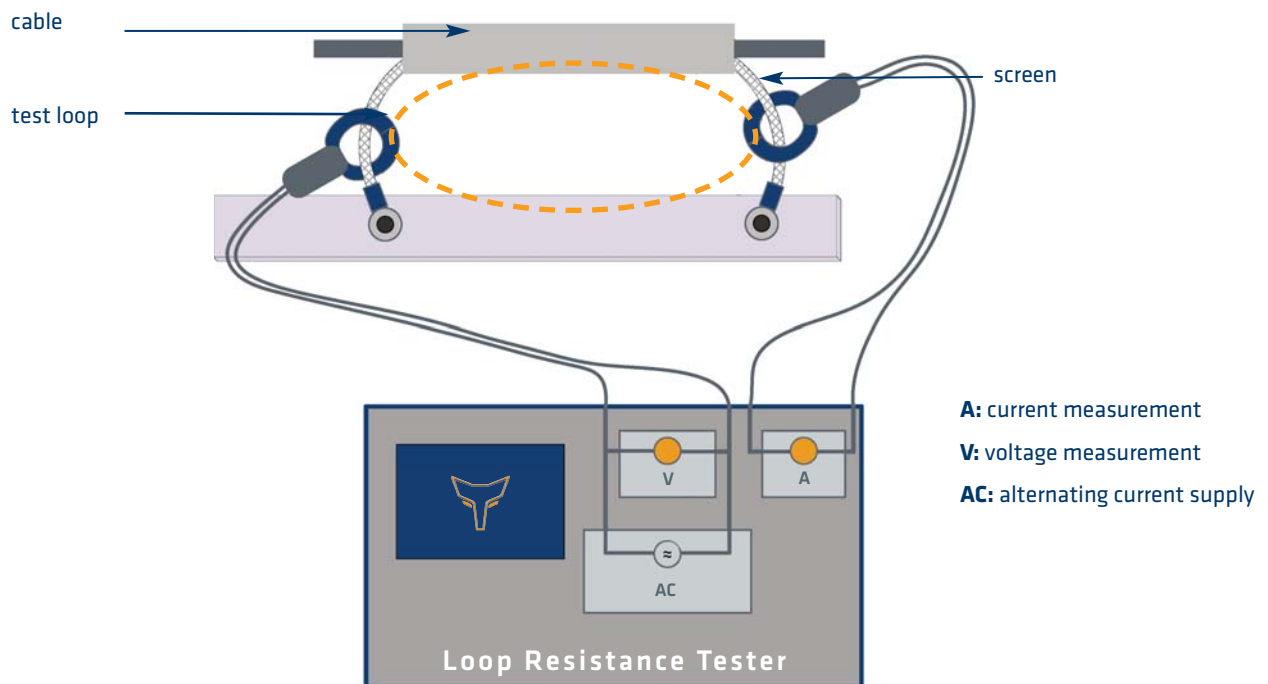

#### Typical Loop Resistance:

2-100 mΩ

#### Operational Method:

Transformer-principle with supply and measurement clamps

#### Supply Frequency:

1 kHz or 2kHz (special design)

The supply clamp induces a current flow in the bonding loop to be tested. A second clamp measures the current in the loop. The measured impedance is the applied voltage calculated together with the measured current. As the loops are not always easily accessible, special or

adapted measurement clamps can be necessary.

TEST-FUCHS has developed impedance measurement clamps for such test purposes. A unique feature, until now not available on the market, is one single clamp that combines a supply and a current measurement clamp. Both functions are screened from one another.

As an alternative, more economic solution, split standard clamps can be used.

Clamps are available with a variety of openings and the cable lengths can of course be supplied in accordance with the customer's requirements.



# Loop Resistance Tester >IM2-FS<

The Loop Resistance Tester >IM2-FS< is designed for fast and simple checking of loop impedance.

- > Especially light and practical design
- > Very large, easy to read display
- > Battery powered, rechargeable in situ or removed
- > Has a galvanically isolated interface for remote control or data exchange
- > Automatic residual current compensation
- > Range is switched automatically
- > Used in conjunction with combined or separate measurement clamps
- > Search mode for rapid location of faulty connections
- > Including self test unit for function control of the test equipment and the measuring clamps



<IM2-FS>  
(TEST-FUCHS item no. 150020605)

## TECHNICAL DATA

Power operation:	1/N/PE AC 50Hz 230V $\pm$ 10%
Battery:	14.4V Li-Ion
Charging time:	6 hours
Measurement range:	depends on clamps max. 200m $\Omega$
Data storage:	90 measured values
Max. resolution:	0.1m $\Omega$
Output voltage:	max 70V

Output current:	max 1A
Meas. frequency:	1kHz $\pm$ 10Hz
Accuracy:	depends on clamps (e.g. <IMZ7> $\pm$ 5% o.m.v., but not less than $\pm$ 2m $\Omega$ )
Dimensions:	approx 25 x 28 x 16cm
Weight of equipment:	approx 5kg

## INCLUDED IN STANDARD SCOPE OF DELIVERY:



**1 Battery**  
"AXCOM"  
(TEST-FUCHS item no. 106220249)

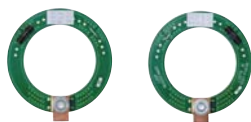

**Self test UUT**  
- L1673-16/000/000 100m $\Omega$   
(TEST-FUCHS item no. 106375848)  
- L1673-6/000/000 10m $\Omega$   
(TEST-FUCHS item no. 106375838)  
- not calibrated



**Shoulder strap "1472"**  
(TEST-FUCHS item no. 106330923)



**Measurement cable set**  
"S307073" with two banana  
plugs and test prods for  
Search Mode  
(TEST-FUCHS item no.  
103191770)



**Power supply unit** incl. power  
cable for charging "S306287"  
(TEST-FUCHS item no. 103070362)



**Travel adapter**  
„SKROSS PRO“  
(TEST-FUCHS item no.  
103206789)

## NOTE:

Measurement clamps are not included in the standard scope of delivery and have to be ordered in accordance with customer requirements.

# Optional Accessories for Loop Resistance Tester >IM2-FS<

## Transport case "FREIGHTAINER PLUS" (TEST-FUCHS item no. 107101334)

Very robust, provided with transport rollers  
Lined with foam  
Storage compartment for:

- Loop Resistance Tester <IM2-FS>
- Charger
- 2 batteries
- Cable bags

Dimensions: approx 60 x 45 x 18 cm  
Weight: approx 9kg



## Battery (TEST-FUCHS item no: 106220249)



Manufacturer: AXCOM  
Model: U-SVLO-99-UD  
Output voltage: 14,5V  
Power: 97Wh  
Intermediate charging possible  
(no memory effect)  
Diagnostic display

## Charger for battery incl. Power Cable (TEST-FUCHS item no: 106220099)

Manufacturer: SWIT  
Model: SC-302S  
Input: AC 100 - 240V; 50 / 60Hz  
Output: DC 14 - 20V; 1.9A  
Possible to charge 2 batteries at the same time



## Recommended Standard Measurement Clamps for Loop Resistance Tester >IM2-FS<

**Note:**

For operation at least one Combined Measurement Clamp or two Single Measurement Clamps are required. The Measurement Clamps are delivered in labeled cable bags.

### IMPEDANCE MEASUREMENT CLAMP

#### <IMZ7>

(TEST-FUCHS item no. 150020514)

- > Symmetric design
- > Capable of being used on cables in a confined area of up to approx 26mm dia
- > Spring loaded to closed (operating) position
- > Combined supply and current measurement clamps
- > Symmetric windings for high repeatability
- > "Measure" button



### TECHNICAL DATA

Frequency:	for test equipments with 1 or 2kHz	Overall dimension (without cable):	Width:	approx. 58mm
Resistance range:	20mΩ, 400mΩ (200mΩ)		Depth:	approx. 31mm
UUT diameter:	max. 26mm		Height:	approx. 120mm
Accuracy:	± 5% o.m.v. but not less than 2mΩ	Jaws opening:		approx. 31mm
Repeatability of UUT variations position in clamp opening:	± 2% of full scale ± 0.5mΩ	Weight:		approx. 500g
		Cable length:		3m

**SUPPLY CLAMP <IMZ5>**

(TEST-FUCHS item no. 150020064)

**CURRENT MEASUREMENT CLAMP <SMZ5>**

(TEST-FUCHS item no. 150020065)

**SET CONSISTS OF <IMZ5> + <SMZ5>**

(TEST-FUCHS item no. 150020607)

- > Modified Fluke i800
- > An IMZ5 Supply Clamp and a SMZ5 Current Measurement Clamp are required for testing
- > Capable of being used on cables and metal rails of up to approx 55mm dia
- > Spring loaded to closed (operating) position
- > Modified Split Standard Clamps
- > An integrated "Measure" button is fitted to the Supply Clamp
- > Both Clamps have arrows showing the current direction



SUPPLY CLAMP IMZ5



CURRENT MEASUREMENT CLAMP SMZ5

**TECHNICAL DATA**

Frequency:	for test equipments with 1 or 2kHz	Overall dimension : (without cable)	Width:	approx 106mm
Resistance range:	20mΩ, 400mΩ (200mΩ)	Jaws opening:	Depth:	approx 40mm
UUT diameter:	max. 55mm	Weight:	Height:	approx 230mm
Accuracy:	± 5% of full scale ± 4 digit	Cable length:		approx 55mm
Repeatability of UUT variations position in clamp opening:	± 3% of full scale ± 1mΩ			approx 1.6kg

**SUPPLY CLAMP <IMZ6>**

(TEST-FUCHS item no. 150020590)

**CURRENT MEASUREMENT CLAMP**

**<SMZ6>**

(TEST-FUCHS item no. 150020589)

**SET CONSISTS OF <IMZ6> + <SMZ6>**

(TEST-FUCHS item no. 150020591)

- > Modified Fluke i200
- > For measurement both one Supply and one Current Measuring Clamps are required
- > Capable of being used on cables and metal rails of up to approx 20mm dia
- > Spring loaded to closed (operating) position
- > Modified Split Standard Clamps
- > An integrated "Measure" button is fitted to the Supply Clamps
- > Both Clamps have arrows showing the current direction



SUPPLY CLAMP IMZ6



CURRENT MEASUREMENT CLAMP SMZ6



**TECHNICAL DATA**

Frequency:	for test equipment with 1 or 2kHz	Overall dimension: (without cable)	Width:	approx. 50mm
Resistance range:	20mΩ, 400mΩ (200mΩ)	Jaws opening:	Depth:	approx. 30mm
UUT diameter:	max. 20mm	Weight:	Height:	approx. 135mm
Accuracy:	± 5% of full scale ± 4 digit	Cable length:		approx. 21mm
Repeatability of UUT variations position in clamp opening:	± 3% of full scale ± 1mΩ			approx. 700g

## IMPEDANCE MEASUREMENT CLAMP <IMZ8>

(TEST-FUCHS item no. 150020608)

- > Symmetric design
- > Capable of being used on cables in a confined area of up to approx 36mm dia
- > Spring loaded to closed (operating) position
- > Combined Supply and Current Measurement Clamps
- > Symmetric windings for high repeatability
- > "Measure" button



### TECHNICAL DATA

Frequency:	for test equipment with 1 or 2kHz	Overall dimension: (without cable)	Width:	approx. 72mm
Resistance range:	20mΩ, 400mΩ (200mΩ)	Jaws opening:	Depth:	approx. 31mm
UUT diameter:	max. 36mm	Weight:	Height:	approx. 134mm
Accuracy:	± 5% of full scale ± 4 digit	Cable length:		approx. 40mm
Repeatability of UUT variations-position in clamp opening:	± 3% of full scale ± 1mΩ			approx. 700g
				3m



## IMPEDANCE MEASUREMENT CLAMP <IMZ9>

(TEST-FUCHS item no. 150020613)

- > Symmetric design
- > Capable of being used on cables in a confined area of up to approx 70mm dia
- > Spring loaded to closed (operating) position
- > Combined Supply and Current Measurement Clamp
- > Symmetric windings for high repeatability
- > "Measure" button

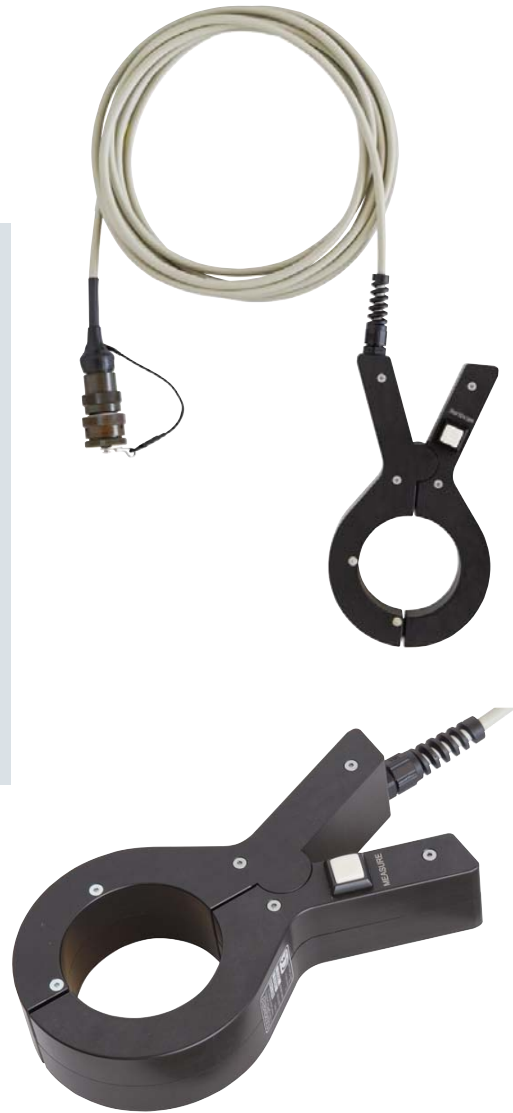

### TECHNICAL DATA

Frequency:	for test equipment with 1 or 2kHz	Overall dimension: (without cable)	Width:	approx 106mm
Resistance range:	20mΩ, 400mΩ (200mΩ)	Jaws opening:	Depth:	approx 40mm
UUT diameter:	max. 66mm	Weight:	Height:	approx 190mm
Accuracy:	± 5% of full scale ± 4 digit	Cable length:		approx 70mm
Repeatability of UUT variations- position in clamp opening:	± 3% of full scale ± 1mΩ			approx 850g

**SPECIAL TO TYPE MODELS ARE AVAILABLE ON REQUEST!**

# Loop Resistance Tester AIRLINER SET

>IM2FSAL1< >IM2FSAL2<



AIRBUS CERTIFIED

Designed for fast and simple checking of loop impedance.

- > Very large, easy to read display
- > Battery powered, rechargeable in situ or removed
- > Galvanically isolated interface for remote control or data exchange
- > ATA Chapter 20-28
- > Automatic residual current compensation
- > Range is switched automatically
- > Search mode for rapid location of faulty connections
- > Including self test unit for function control of the test equipment and the measuring clamps
- > Equivalent AIRBUS P/N TS11194

## TECHNICAL DATA

Power operation:	1/N/PE AC 50/60Hz 100 - 240V	Output voltage:	max 70V
Battery:	14.4V Li-Ion	Output current:	max 1A
Charging time:	6 hours	Meas. frequency:	1kHz ± 10Hz
Measurement range up to:	400mΩ	Accuracy:	depends on clamps (e.g. >IMZ7< ±5% o.m.v., but not less than ±2mΩ)
Data storage:	90 measured values	Dimensions:	approx 25 x 28 x 16cm
Max. resolution:	0.1mΩ	Weight of equipment:	approx 5kg

## Included in standard scope of delivery

### Self test UUT

L1673-20A 200mΩ  
(TEST-FUCHS item no. 106375852)

L1673-6A 10mΩ  
(TEST-FUCHS item no. 106375838)

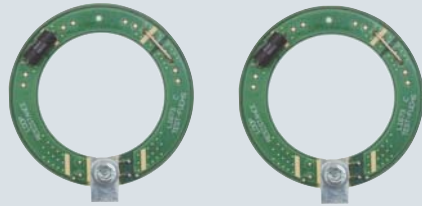

### Measurement cable set "S307073" (TEST-FUCHS item no. 103191770)

with two banana plugs and  
test prods for Search Mode



### Power-supply-unit "S1311202" (TEST-FUCHS item no. 103070831)

incl. power cable for charging



### Battery "AXCOM" (TEST-FUCHS item no. 106220249)



### Shoulder strap "1472" (TEST-FUCHS item no. 106330923)



## Accessories for Loop Resistance Tester

### >IM2FSM2<

#### Transport case "EXPLORER" (TEST-FUCHS item no. 107102007)

Very robust, provided with transport rollers lined with foam  
Storage compartment for:

- Loop Resistance Tester >IM2FSM2<
- Charger
- 1 battery
- 3 different clamps

Dimensions: approx 60 x 45 x 33 cm  
Weight: approx 12.5kg



#### Charger for battery incl. Power Cable (TEST-FUCHS item no: 106220099)

Manufacturer: SWIT  
Model: SC-302S  
Input: AC 100 - 240V; 50/60Hz  
Output: DC 14 - 20V; 1.9A  
Possible to charge 2 batteries at the same time



# Standard Measurement Clamps for Loop Resistance Test Set >IM2FSAL1<

## SUPPLY CLAMP >IMZ6<

(TEST-FUCHS item no. 150020590)

## CURRENT MEASUREMENT CLAMP

### >SMZ6<

(TEST-FUCHS item no. 150020589)

- > For measurement both one Supply and one Current Measuring Clamps are required
- > Apt for use on cables and metal rails of up to approx. 20mm diameter
- > Spring loaded to closed (operating) position
- > Modified Split Standard Clamps Fluke i200
- > Integrated "Measure" button on Supply Clamps
- > Both clamps have arrows showing the current direction

## SET CONSISTS OF >IMZ6< + >SMZ6<

(TEST-FUCHS item no. 150020591)



Supply Clamp >IMZ6<



Current Measurement Clamp >SMZ6<



## TECHNICAL DATA

Frequency:	for test equipment with 1kHz	Overall dimension:	Width: approx. 50mm
Resistance range:	400mΩ	(without cable)	Depth: approx. 30mm
UUT diameter:	max. 20mm		Height: approx. 135mm
Accuracy:	5% o.m.v. but not less than 2mΩ	Jaws opening:	approx. 21mm
Repeatability of UUT variations position in clamp opening	± 3% of full scale ± 1mΩ	Weight:	approx. 700g
		Cable length:	3m

>IM2FSAL1< >IM2FSAL2<

# Standard Measurement Clamps for Loop Resistance Test Set >IM2FSAL2<

## Note:

For operation at least one Combined Measurement Clamp or two Single Measurement Clamps are required. The Measurement Clamps are delivered in labelled cable bags.

## IMPEDANCE MEASUREMENT CLAMP

### >IMZ7<

(TEST-FUCHS item no. 150020514)

- > Symmetric design
- > Apt for use on cables in a confined area of up to approx. 26mm diameter
- > Spring loaded to closed (operating) position
- > Combined Supply and Current Measurement Clamps
- > Symmetric windings for high repeatability
- > "Measure" button



Supply Clamp >IMZ7<



## TECHNICAL DATA

Frequency:	for test equipment with 1kHz	Overall dimension (without cable):	Width:	approx. 58mm
Resistance range:	400mΩ		Depth:	approx. 31mm
UUT diameter:	max. 26mm		Height:	approx. 120mm
Accuracy:	± 5% o.m.v. but not less than 2mΩ	Jaws opening:		approx. 31mm
Repeatability of UUT variations position in clamp opening ± 2% of full scale ± 0.5mΩ		Weight:		approx. 500g
		Cable length:		3m

>IM2FSAL1< >IM2FSAL2<



# Optional Measurement Clamps for Loop Resistance Test Set >IM2FSAL1< and >IM2FSAL2<

## SUPPLY CLAMP >IMZ5<

(TEST-FUCHS item no. 150020064)

## CURRENT MEASUREMENT CLAMP >SMZ5<

(TEST-FUCHS item no. 150020065)

## SET CONSISTS OF >IMZ5< + >SMZ5<

(TEST-FUCHS item no. 150020607)

- > An IMZ5 Supply Clamp and a SMZ5 Current Measurement Clamp are required for testing
- > Apt for use on cables and metal rails of up to approx. 55mm diameter
- > Spring loaded to closed (operating) position
- > Modified Split Standard Clamps Fluke i800
- > Integrated "Measure" button on the Supply Clamp
- > Both clamps have arrows showing the current direction



Supply Clamp >IMZ5<



Detailed picture of the Standard Clamp Fluke i800



Current Measurement Clamp >SMZ5<

## TECHNICAL DATA

Frequency:	for test equipment with 1 or 2kHz	Overall dimension:	Width:	approx. 106mm
Resistance range:	400mΩ	(without cable)	Depth:	approx. 40mm
UUT diameter:	max. 55mm		Height:	approx. 230mm
Accuracy:	± 5% o.m.v. but not less than 2mΩ	Jaws opening:		approx. 55mm
Repeatability of UUT variations position in clamp opening	± 3% of full scale ± 1mΩ	Weight:		approx. 1.6kg
		Cable length:		3m

>IM2FSAL1< >IM2FSAL2<

# Antistatic Paint Testers

To dissipate electrostatic charges, all outer non-conductive surfaces of the aircraft are painted with a conductive coating (antistatic paint). On top of this coat there is a layer of non-conductive, anti-corrosion paint.

The antistatic paint must be tested for conductivity as well as its adhesion without damaging the coatings.

These measurements are carried out with special flexible measuring heads, matching the aircraft's contours. The measuring heads are used in combination with the TEST-FUCHS Antistatic Paint Tester <IA2>.

The Antistatic Paint Tester enables quick, easy and accurate testing of the surface and volume resistances of the aircraft's exterior surfaces.

## COMPOSITION OF ANTISTATIC PAINT

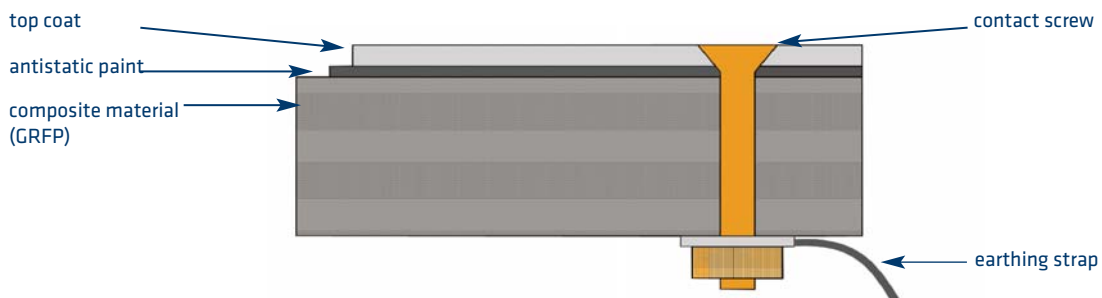

### Measurement mode S 1:

Measurement of surface resistance through insulating layers:

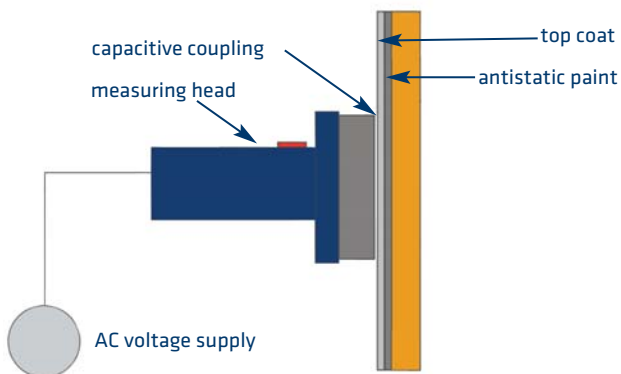

Typical measured values:  
20 kOhm to 2 MOhm (volume resistance)

Measurement frequency:  
20 kHz

### Measurement mode B 1:

Measurement of resistance from the measurement point of the structure connection (volume resistance):

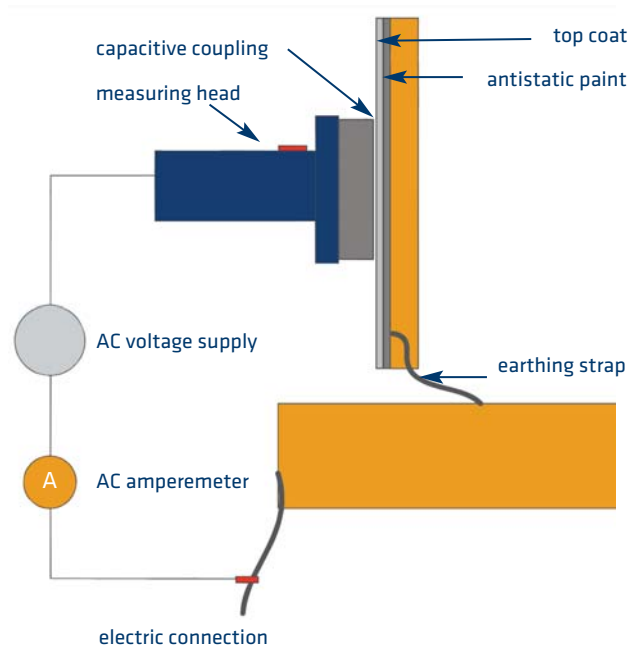

There are flexible measuring heads for various contours of different aircraft!

# Anti Static Paint Tester

>IA2<



>IA2<  
(TEST-FUCHS item no. 150020606)

The Anti Static Paint Tester is designed for fast and simple testing of conductive layers and their bonding.

- > Light, practicable test equipment
- > Battery powered, rechargeable in situ or removed
- > Measurement of surface resistance through insulated layers (Mode S1)
- > Measurement of contact resistance (Mode B1) to the structure connection through insulated layers
- > Automatic field switching

## GENERAL INFORMATION

- > Has a galvanically isolated interface for remote control or data exchange
- > Specific measuring heads conforming to curved surfaces
- > Visual and acoustic signals for over/under limit values
- > Incl. self test unit for function control of the test equipment and the measuring heads

## TECHNICAL DATA

> General informations:	> Dimensions and weight:
Power operation with power supply: 1/N/PE AC 50Hz 230V ± 10%	Length: approx. 25cm Width: approx. 13cm Height: approx. 16cm
Battery life: > 200 measurements Battery: 7.2V Li-Ion Charging time: 6 hours	Weight: 2.5kg
Measurement mode: S1: Surface-Surface B1: Surface-Structure	
Measurement range S1: depends on sensor Measurement range B1: depends on sensor	
Measuring frequency: 20kHz	
Accuracy: ± 10% of reading ± 2 digit	

### INCLUDED IN STANDARD SCOPE OF DELIVERY:



### NOTE:

The required measuring head is not included in the standard scope of delivery.

## Optional Accessories For Antistatic Paint Tester >IA2<

### Transport case "EXPLORER" (TEST-FUCHS item no. 107101335)

Very robust, stackable

Lined with foam

Storage compartment for:

- Anti-Static Paint Tester <IA2>
- Accessories
- Documentation

Dimensions: 58 x 44 x 16cm

Weight: approx. 5kg



### Battery (TEST-FUCHS item no. 106220110)



Manufacturer: TEST-FUCHS  
Model: 5307149  
Output voltage: 7.2V  
Power: 48Wh  
Intermediate charging possible (no memory effect)  
The equipment is fitted with one battery

### External charger for 2 batteries incl. power cable (TEST-FUCHS item no. 106220111)

Manufacturer: SWIT  
Model: SC-3602F  
Input: AC 100 to 240V; 50 / 60Hz  
Output: DC 7 to 8.4V; 1.8A  
Possible to charge 2 batteries at the same time



# Recommended Standard Measuring Head For Anti Static Paint Tester >IA2<

<IATP3> Specially optimized for use in Measurement Mode B1  
(TEST-FUCHS item no. 150020603)

Dimensions:	Ø 76 x 130mm	
Connecting cable	3m	
Measurement range:	B1: 20kΩ bis 2MΩ	
Accuracy:	±10% ±2 digit of reading	
MAX-LED at head	YES	
Measurement button:	YES	
Max. paint thickness:	1mm	
Test surface:	Max. radius 200mm	
Contact pressure:	0.2 to 2kg (2 to 20N) alternative	
Special feature:	Skydrol resistant	

## BONDING CABLES

**Bonding Cable Extension 5m PKL320-2**  
(TEST-FUCHS item no. 103240318)



**Measuring Head Cable Extension 10m PKL320-3**  
(TEST-FUCHS item no. 103240319)



**NOTE:**

Other measuring heads and special designs are available on request!



## Bonding And Loop Resistance Tester

## &gt;BLRT2-XX-X&lt;



<BLRT2>  
TEST-FUCHS part no. 151020031

## AIRBUS CERTIFIED

The equipment is developed as multifunctional bonding tester. It is especially used in aircraft manufacturing. It can be used on all aircraft types. It is capable of performing various tests depending on used accessories.

The test capability ranges from simple 4-wire bonding tests to loop resistance testing using current clamps with or without current measuring clamps up to special tests e.g. ESN tests (electrical structure network) or bonding test of multiple connected earth connections.

- > All testing features can be selected and combined independently. Options can also be retrofitted at a later stage
- > The tester is housed in a light and practical case with handle ensuring easy handling by the user
- > The high capacity accumulator ensures that the equipment can be used for long periods of time
- > A wide range of accessories is available for this tester

## GENERAL INFORMATION

- > Large display for good readability
- > User friendly software for easy operator use
- > Multi-function tester with selectable standard and special functions
- > Clamps and cables are coded
- > USB interface
- > Memory capacity for 1,000 measuring values (including date and time)
- > PC-Software for data processing is available
- > Including self test unit for function control of the test equipment and the measuring clamps

## TECHNICAL DATA

<p>&gt; <b>Electrical supply (requirements):</b></p> <p>Mains charger adapter: 1/N/PE AC 50Hz                      Accumulator: 2 x Li-Ion 7.2V 47.5Wh</p>	<p>&gt; <b>Interface:</b></p> <p>Interface: USB (Mini USB)                      Memory capacity: min. 1,000 measuring values</p>
<p>&gt; <b>Functions:</b></p> <p>Measuring functions: see "FUNCTIONS"                      Ranges: see "OPTIONS"                      Accuracy: see "OPTIONS"</p>	<p>&gt; <b>Operating conditions (operation):</b></p> <p>Temperature: -15°C to +50°C (+5°F to +122°F)                      does not apply to all measuring functions                      +10°C to +50°C (+50°F to +122°F)                      for "Single Clamp Measurement"</p> <p>Rel. humidity: max. 95% relative humidity                      (non-condensing)</p>
<p>&gt; <b>Output values:</b></p> <p>Output voltage DC: max. 7VDC                      Output current DC: max. 10ADC                      Output voltage AC: max. 40VAC                      Output power AC: max. 30W</p>	<p>&gt; <b>Operating conditions (storage):</b></p> <p>Temperature: -20°C to +70°C (-4°F to 158°F)                      Rel. humidity: max. 95% relative humidity                      (non-condensing)</p>
<p>&gt; <b>Measurement range:</b></p> <p>Functions: Measurement ranges and tolerances are listed in the item "FUNCTIONS"</p> <p>Battery voltage: Range: 0 to 10V                      Tolerance: 0.5% of reading</p>	<p>&gt; <b>Dimensions and weight:</b></p> <p>Width: approx. 250mm (9.8in)                      Depth: approx. 170mm (6.7in)                      Height: approx. 170mm (6.7in)                      Weight: approx. 3.2kg (7.1lb)</p>

## FUNCTIONS

**BONDING TESTER (OPTION B)**

(TEST-FUCHS part no. 151020036)

**> Technical description**

Bonding Tester with 10A, 1A and 0.1A test current. It works as a Kelvin Resistance Meter.

The bonding tester measures the resistive connection between two measuring points.

During the bonding test an increased test current is injected in the unit under test by means of test probes or terminals. The voltage drop is recorded on two test points. The contact resistance between voltage test points is calculated by means of current and voltage values.

This measuring method only works when the total measurement current flows through the unit under test.

Schematic diagram of the test set-up

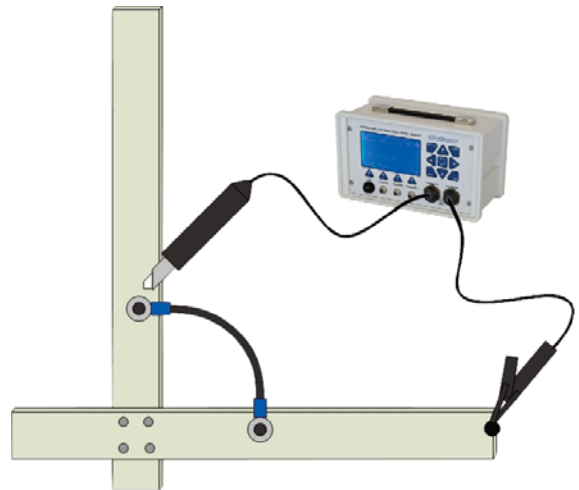
**BONDING TEST FOR MULTIPLE CROSSED CONNECTIONS (UP TO 20A) (OPTION C)**

(TEST-FUCHS part no. 151020037)

**> Technical description**

This bonding test is carried out when the injected test current can flow through different paths and there is a physical access to the unit under test.

The test current is injected by means of a "Current Injection Clamp" (CIC). Here a loop resistance is necessary. The "Current Measurement Clamp" (CMC) measures this test current. The voltage drop at the UUT is measured by means of a pair of voltage test probes. The injected current which is not flowing through the unit under test is measured by means of an additional "Current Measurement Clamp" (CMC) and is taken into account at the calculation.

The contact resistance is determined by means of measured currents and voltage drop.

Schematic diagram of the test set-up

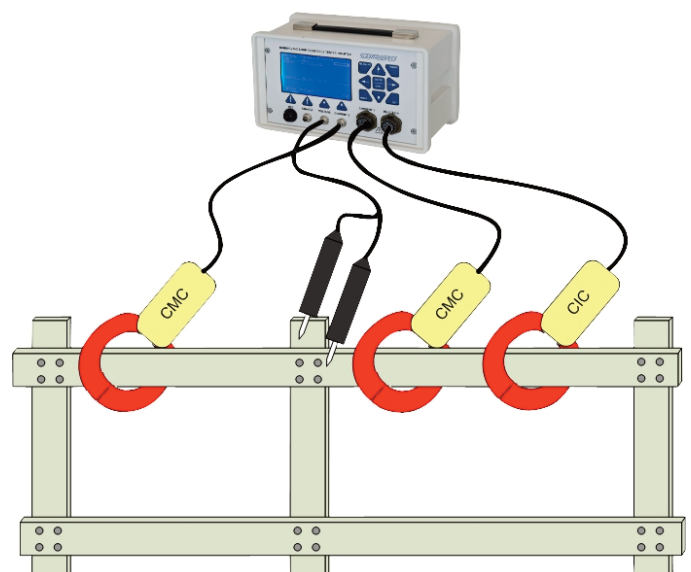

## FUNCTIONS

**HIGH CURRENT / LOW FREQUENCY MICRO-OHMMETER (OPTION E)**

(TEST-FUCHS part no. 151020038)

**> Technical description**

The “High Current / Low Frequency Test” (up to 150A and with different frequencies) is used to evaluate the quality of the connections.

The very high test current with low frequency is injected by means of a “Current Injection Clamp” (CIC) For this purpose a loop resistance is necessary. A “Current Measurement Clamp” (CMC) measures this test current. The voltage drop at the UUT is measured by a pair of voltage test probes. The contact resistance is determined by means of test current and voltage drop.

Schematic diagram of the test set-up

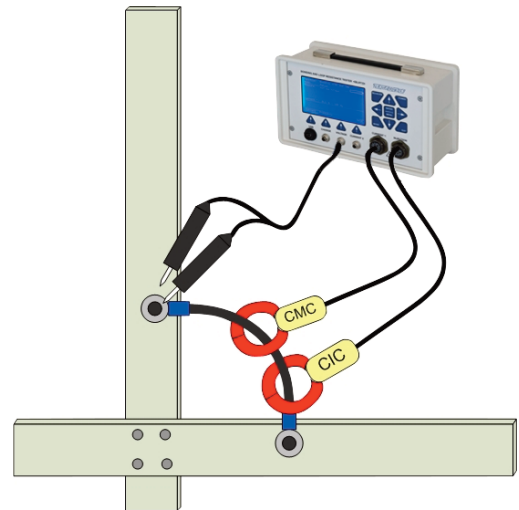
**LOOP RESISTANCE TEST (OPTION L, M, N)**

(TEST-FUCHS part no. 151020039 for option L - 1,000Hz)

(TEST-FUCHS part no. 151020040 for option M - 2,000Hz)

(TEST-FUCHS part no. 151020041 for option N - 100 to 200Hz)

**> Technical description**

The “Loop Resistance Test” measures the overall resistance of a bonding loop. It is used for example when a metal tube has multiple connections to structure.

A “Current Injection Clamp” (CIC) injects alternating current into the current loop and the required voltage is measured. A “Current Measurement Clamp” (CMC) measures the injected current. The overall resistance of the current loop is calculated by means of voltage and current value.

For this method it is essential that there is only one current loop.

Schematic diagram of the test set-up

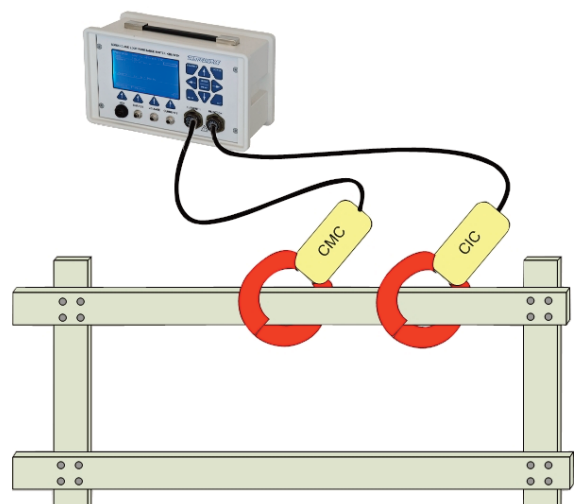

## FUNCTIONS

**OVERBRAID TEST (OPTION O)**

(TEST-FUCHS part no. 151020042)

**> Technical description**

The Overbraid Test verifies whether bonding connections (e.g. of a shielding braid) are properly connected to the structure.

The test current of up to 10A is injected by means of the "Current Injection Clamp" (CIC). For this purpose a loop resistance is necessary. A "Current Measurement Clamp" (CMC) measures this test current. The voltage drop at the connection is measured by means of a pair of voltage test probes. The contact resistance is determined by means of test current and voltage drop.

This test method is similar to option E however lower currents are used in this case.

Schematic diagram of the test set-up

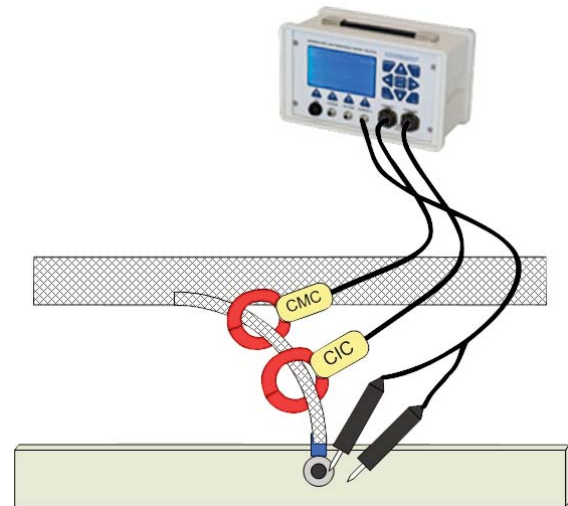
**HIGH RESISTANCE LOOP TEST (OPTION P)**

(TEST-FUCHS part no. 159060017)

**> Technical description**

With this bonding test, the loop impedance and ohmic resistance are determined, also if these are rather high (< 4 Ohm). In addition the ohmic resistance on one connection can be determined by choice .

By means of the "Current Injection Clamp" (CIC), the test current is injected. For this purpose, a loop resistance is necessary. The required voltage is measured. A "Current Measurement Clamp" (CMC) measures the test current. The impedance and the ohmic resistance of the loop are calculated with these voltage and current values.

In addition, the voltage drop at the connection can be measured by means of a pair of voltage test probes. In this case the ohmic resistance of the connection is determined.

Schematic diagram of the test set-up

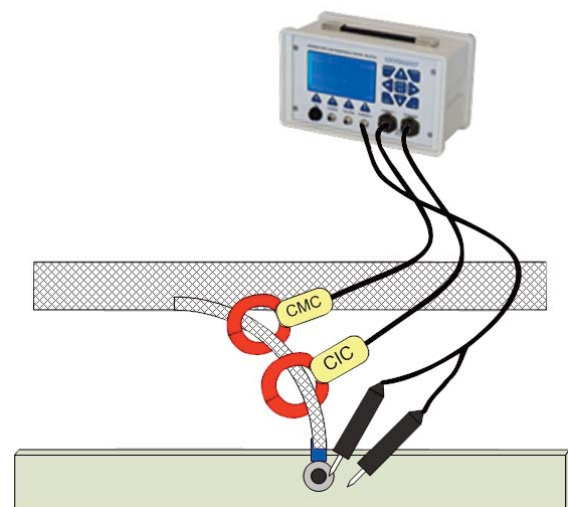

## FUNCTIONS

**MICRO-OHMMETER WITH SEPARATE CURRENT MEASUREMENT CLAMP (OPTION S)**

(TEST-FUCHS part no. 151020043)

**> Technical description**

This bonding test is carried out when the injected test current can use different paths and there is a physical access to the unit under test (also for the current measuring clamp). When this is not the case, option C can be used instead.

This bonding test operates like a standard bonding test (option B), in addition the real UUT current is measured by means of a „Current Measurement Clamp“.

The result is the contact resistance of the connection element which is located between the voltage probes and which is enclosed by the current probe.

Schematic diagram of the test-setup

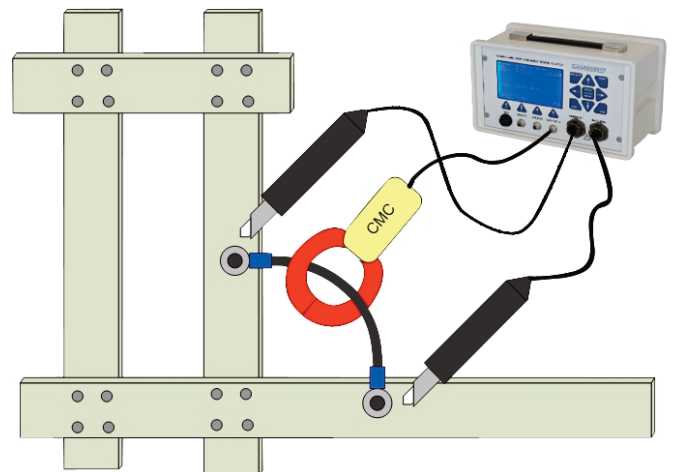



## FUNCTIONS

**WIRELESS COMMUNICATION (OPTION V)**

(TEST-FUCHS part no. 151020044)

**> Technical description**

Automatic wireless transfer of data between the <BLRT2> and a PC can be performed. For this purpose a RF USB stick is inserted into the PC.

**SINGLE CLAMP MEASUREMENT (OPTION Y)**

(TEST-FUCHS part no. 151020045)

**> Technical description**

Single Clamp Measurement for the options E and N.

Many of the functions require one "Current Injection Clamp" (CIC) and one "Current Measurement Clamp" (CMC). When, due to space restrictions, it is not possible to attach two clamps to the unit under test, the "Single Clamp Measurement" method can be used. In this case only one clamp is used (to inject the current). The injected current is calculated using the operating parameters. The advantage of this method is that measurements can easily be carried out and the number of clamps is reduced to one. The disadvantage is that the measurement accuracy is reduced by approx. +2% of reading (depends on the used function).

Schematic diagram of the test set-up

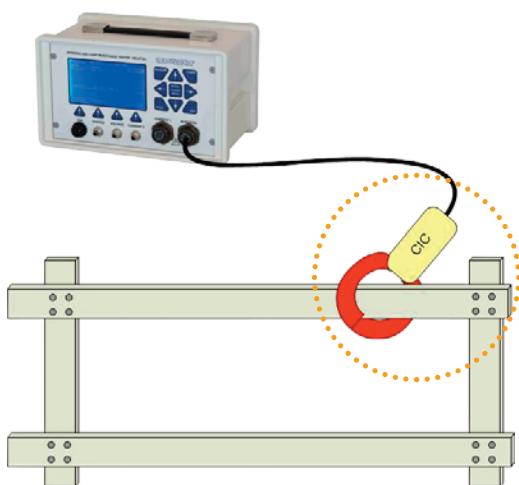

Loop Resistance  
Test (Option L, M, N)  
Single Clamp Measurement

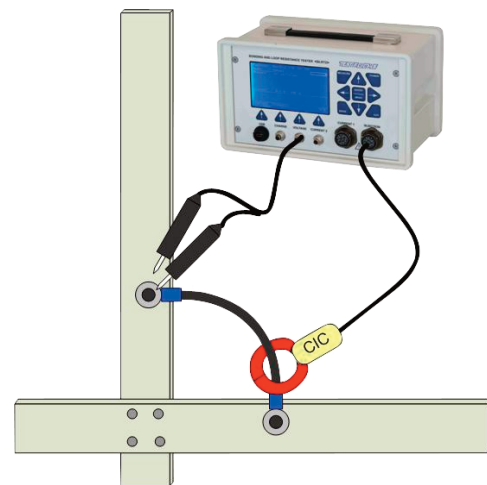

High Current / Low Frequency  
Test (Option E)  
Single Clamp Measurement

## FUNCTIONS

### CAPACITIVE MEASUREMENT (OPTION Z)

(TEST-FUCHS part no. 151020046)

#### > Technical description

Voltage probes must have a conductive connection to the metal. Therefore it might be necessary to break through the varnish coating of the UUT which will require renewal after test completion.

To avoid this extensive process it is possible to use capacitive voltage measurement instead of the voltage probes. This can replace one or both voltage measurements. This test method can only be used for AC measurements.

Due to the capacitive measurement system, the accuracy of measurements is reduced by approx. +3% (depending on the used function).

Schematic diagram of the sensor

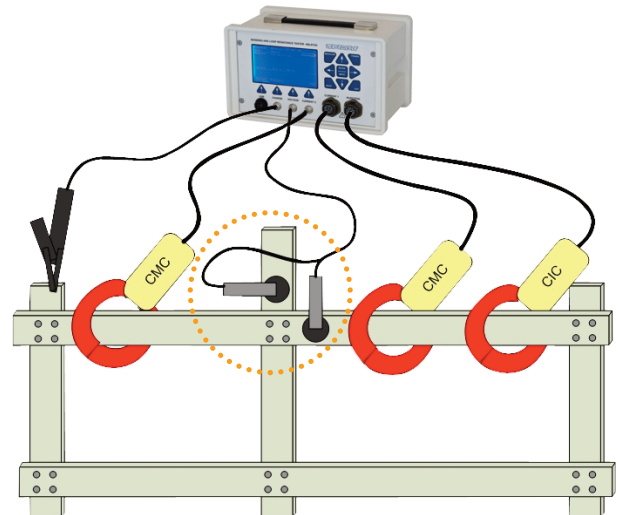

## TYPE KEY

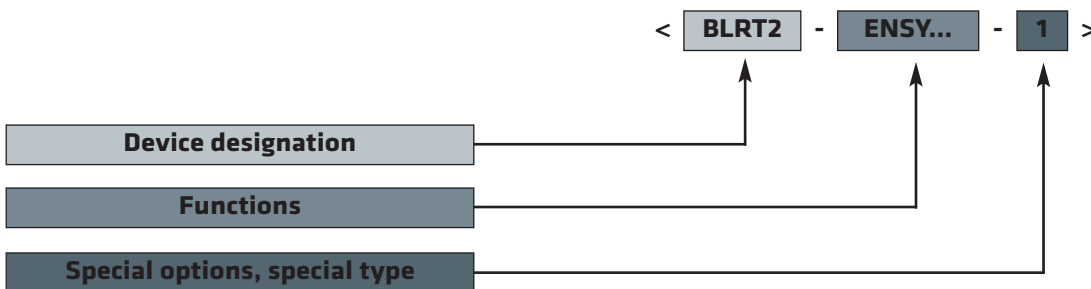

OPTIONS

Option	Function	TEST-FUCHS part no.	Measurement (mOhm)	Resolution (µOhm)	Adjustable current (A)	Frequency (Hz)	Standard accuracy (% of reading)	Required accessories	Remarks
<b>B</b>	Bonding Tester	151020036	2 to 1000 at 0.1A	1	0.1 1 10	DC	0.2% reading +0.2% final v.	2 x Kelvin Probe	(available) Standard Bonding
<b>C</b>	Bonding Test for Multiple Crossed Connections	151020037	0.01 to 100	1	10 20	1000	10 ±2µOhm	1 x Voltage Probe 1 x Current Injection Clamp 2 x Current Measurement Clamp	(under development)
<b>E</b>	High Current / Low Frequency Micro-Ohmmeter	151020038	Rc: 0.005 to 0.5 Zloop: 0.1 to 20	0.1	10 20 50 100 150	100 200	Rc: 10 ±1µOhm Zloop: 10±20µOhm	1 x Current Injection Clamp 1 x Current Measurement Clamp or 1 x Combined Injection Measurement Clamp and 1 x Voltage Probe	(available) e.g.: used for ESN Measurement
<b>L</b>	Loop Resistance Tester 1000Hz	151020039	1 to 200	10	1 10	1000	5 ±50µOhm	1 x Current Injection Clamp 1 x Current Measurement Clamp or 1 x Combined Injection Measurement Clamp	(available) Standard Loop Resistance Test
<b>M</b>	Loop Resistance Tester 2000Hz	151020040	1 to 200	10	1 10	2000	5 ±50µOhm	1 x Current Injection Clamp 1 x Current Measurement Clamp or 1 x Combined Injection Measurement Clamp	(development is planned)
<b>N</b>	Loop Resistance Tester 100Hz	151020041	0.1 to 20	1	0.1 1 10	100 200	10 ±20µOhm	1 x Current Injection Clamp 1 x Current Measurement Clamp or 1 x Combined Injection Measurement Clamp	(available) e.g.: used for ESN Measurement
<b>O</b>	Overbraid Test	151020042	Rc: 0.005 to 0.5 Zloop: 0.1 to 20	1	0.1 1 10	100 200	Rc: 10 ±1µOhm Zloop: 10 ±20µOhm	1 x Current Injection Clamp 1 x Current Measurement Clamp or 1 x Combined Injection Measurement Clamp and 1 x Voltage probe	(available)
<b>P</b>	High Loop Resistance Tester	159060017	Zloop: 1 to 4000 Rc: 0.01 to 4000	10 or 1000	max. 1	200	5 ±0.2µOhm Rc: ±5 % reading or 0.2µOhm	1 x Current Injection Clamp 1 x Current Measurement Clamp or 1 x Combined Injection Measurement Clamp	(available)
<b>S</b>	Micro-Ohmmeter with separate Current Measurement Clamp	151020043	0.1 to 10	1	0.1 1 10	DC	10	2 x Kelvin Probe 1 x Current Measurement Clamp	(available) e.g.: used for ESN Measurement
<b>V</b>	Wireless communication	151020044				858MHz		RF USB Stick for Computer	RF 858MHz (development is planned)
<b>Y</b>	Single Clamp Measurement	151020045					additional 2%	only Current Injection Clamp required	(available) In combination with one of these options: E, L, M, N, O
<b>Z</b>	Capacitive Measurement	151020046					additional 3%		In combination with one of these options: E, O (development is planned)

# Standard Accessories For Bonding And Loop Resistance Tester

## >BLRT2-XX-X<

### Battery Package

#### (2 batteries "S307149")

(TEST-FUCHS part no. 106220138)

Manufacturer:	TEST-FUCHS
Type:	S307149
Output voltage:	7.2V
Power:	48Wh
Current output:	min. 6A
Intermediate charging is possible (no memory effect)	



### Power Supply Unit "S307164"

(TEST-FUCHS part no. 103070582)



### Shoulder Strap

#### Type "1472"

(TEST-FUCHS part no. 106330923)



### Self Test Unit

(TEST-FUCHS part no. 106375881)

Manufacturer: TEST-FUCHS  
Type: L1708/000/000  
Functions: E, S, N  
not calibrated



### Connection Cable Mini USB B-A 2m

(TEST-FUCHS part no. 106331470)



### Travel adapter

(„SKROSS PRO“)

(TEST-FUCHS part no. 103206789)



## Optional Accessories For Bonding And Loop Resistance Tester

### >BLRT2-XX-X<

#### Storage Case "EXPLORER 8.850-W"

(TEST-FUCHS part no. 150090174)

With wheels and extendable handle  
Very solid and stackable  
Inside coated with foam  
Compartments for: - BONDING AND LOOP RESISTANCE  
TESTER <BLRT2-XX-X>  
- Various accessories  
- Technical documentation  
Dimensions: approx. 650 x 500 x 250mm  
(approx. 25.6 x 19.7 x 9.8in)  
Weight (empty): approx. 5kg (approx. 11.0lb)



#### Standard Battery Charger

(TEST-FUCHS part no. 103230267)

Manufacturer: TEST-FUCHS  
Type: S274257  
Input: AC 100 to 240V; 50 / 60Hz  
Output: DC 7 to 8.4V; 1.8A  
Loading time: approx. 4h (90%)  
Two batteries can be charged at the same time



#### Extended Battery Charger

(TEST-FUCHS part no. 103070532)

Manufacturer: TEST-FUCHS  
Type: S307139  
Input: AC 100 to 240V; 50 / 60Hz  
Output: DC 12 to 17V; 10A  
Loading time: approx. 1.5h (90%)  
Two batteries can be charged at the same time





## Body Strap

### Type „1-8151“

(TEST-FUCHS part no. 106331548)



## Small Current Injection Clamp <CIC1>

(TEST-FUCHS part no. 151020047)

Manufacturer:	Fluke modified by TEST-FUCHS
Inner diameter:	21mm (0.8in)
Length:	135mm (5.3in)
Width of the clamp:	18mm (0.7in)
Width of the clamp housing:	28mm (1.1in)
Height:	48mm (1.9in)
Weight:	494g (1.1lb)
Cable length:	4m (157.5in)
Windings, primary:	180
Windings, measurement:	30
Supply max. 100Hz:	7.2V
Supply max. 200Hz:	13.5V
Supply max. 400Hz:	22V
Uloop max. 100Hz:	36mV
Uloop max. 200Hz:	67.5mV
Uloop max. 400Hz:	110mV
Uloop max. 1000Hz:	185mV
Uloop max. 2000Hz:	205mV
Clamp Open Detection:	not included
Integr. temperature sensor:	not included



## Big Current Injection Clamp <CIC2>

(TEST-FUCHS part no. 151020049)

Manufacturer:	Metrel modified by TEST-FUCHS
Inner diameter:	55mm (2.2in)
Length:	170mm (6.7in)
Width of the clamp:	36mm (1.4in)
Width of the clamp housing:	36mm (1.4in)
Height:	97mm (3.8in)
Weight:	877g (1.9lb)
Cable length:	4m (157.5in)
Windings, primary:	180
Windings, measurement:	30
Supply max. 100Hz:	16.5V
Supply max. 200Hz:	30V
Supply max. 400Hz:	37V
Uloop max. 100Hz:	82.5mV
Uloop max. 200Hz:	150mV
Uloop max. 400Hz:	185mV
Clamp Open Detection:	not included
Integr. temperature sensor:	not included



## Small Current Injection Clamp For Single Clamp And Clamp-Open Detection And Temperature Sensor <CIC5>

(TEST-FUCHS part no. 151020059)

Manufacturer:	Fluke modified by TEST-FUCHS
Inner diameter:	23mm (0.9in)
Length:	135mm (5.3in)
Width of the clamp (reduced):	13mm (0.5in)
Width of clamp housing:	28mm (1.1in)
Height:	48mm (1.9in)
Weight:	494g (1.1lb)
Cable length:	4m (157.5in)
Windings, primary:	180
Windings, measurement:	30
Supply max. 100Hz:	7.2V
Supply max. 200Hz:	13.5V
Supply max. 400Hz:	22V
Uloop max. 100Hz:	36mV
Uloop max. 200Hz:	67.5mV
Uloop max. 400Hz:	110mV
Clamp Open Detection:	included
Integr. temperature sensor:	included



## Big Current Injection Clamp For Single Clamp And Clamp-Open Detection And Temperature Sensor <CIC8>

(TEST-FUCHS part no. 150020835)

Manufacturer:	Metrel modified by TEST-FUCHS
Inner diameter:	55mm (2.2in)
Length:	170mm (6.7in)
Width of the clamp (rear):	36mm (1.4in)
Width of the clamp (front):	25mm (1.0in)
Width of the clamp housing:	36mm (1.4in)
Height:	97mm (3.8in)
Weight:	877g (1.9lb)
Cable length:	4m (157.5in)
Windings, primary:	180
Windings, measurement:	30
Supply max. 100Hz:	16.5V
Supply max. 200Hz:	30V
Supply max. 400Hz:	37V
Uloop max. 100Hz:	82.5mV
Uloop max. 200Hz:	150mV
Uloop max. 400Hz:	185mV
Clamp Open Detection:	included
Integr. temperature sensor:	included



### Small Current Measurement Clamp <CMC1>

(TEST-FUCHS part no. 151020048)

Manufacturer:	Fluke modified by TEST-FUCHS
Inner diameter:	21mm (0.8in)
Length:	135mm (5.3in)
Width of the clamp:	18mm (0.7in)
Width of the clamp housing:	28mm (1.1in)
Height:	48mm (1.9in)
Weight:	494g (1.1lb)
Cable length:	4m (157.5in)
Windings, primary:	1,000
Max. current measurement:	150A



### Big Current Measurement Clamp <CMC2>

(TEST-FUCHS part no. 151020050)

Manufacturer:	Metrel modified by TEST-FUCHS
Inner diameter:	55mm (2.2in)
Length:	170mm (6.7in)
Width of the clamp:	36mm (1.4in)
Width of the clamp housing:	36mm (1.4in)
Height:	97mm (3.8in)
Weight:	877g (1.9lb)
Cable length:	4m (157.5in)
Windings, primary:	1,000
Max. current measurement:	150A



**Active Clamp <CMC3>**

(TEST-FUCHS part no. 151020051)

Active, small AC and DC current measurement clamp

Supplied by the &lt;BLRT2&gt; thus batteries are not required

The switch and regulator that are fitted on the clamp are deactivated and have no influence on the operation

Manufacturer:	Fluke modified by TEST-FUCHS
Inner diameter:	20mm (0.8in)
Length:	180mm (7.1in)
Width of the clamp:	15mm (0.6in)
Width of the clamp housing:	25mm (1.0in)
Height:	70mm (2.8in)
Weight:	326g (0.7lb)
Cable length:	4m (157.5in)
Proportion:	10mV/A AC and DC
Max. current measurement:	10A

**Small Current Measurement Clamp - Reduced Size <CMC6>**

(TEST-FUCHS part no. 150090173)

Manufacturer:	Fluke modified by TEST-FUCHS
Inner diameter:	23mm (0.9in)
Length:	135mm (5.3in)
Width of clamp (reduced):	13mm (0.5in)
Width of clamp housing:	28mm (1.1in)
Height:	48mm (1.9in)
Height of a clamp arm (reduced):	8.5mm (0.3in)
Weight:	494g (1.1lb)
Cable length:	4m (157.5in)
Windings, primary:	1.000
Max. current measurement:	150A





## Small Combined Injection / Measurement Clamp <CIMC7>

(TEST-FUCHS part no. 151020052)

Manufacturer:	TEST-FUCHS
Inner diameter:	26mm (1.0in)
Length:	175mm (6.9in)
Width of clamp:	31mm (1.2in)
Width of clamp housing:	31mm (1.2in)
Height:	62mm (2.4in)
Height of a clamp arm:	16mm (0.6in)
Weight:	494g (1.1lb)
Cable length:	4m (157.5in)
Windings, primary:	360
Max. current measurement:	
- Voltage measurement:	60
- Current measurement:	1100
Maximal supply 1 kHz:	30V
Maximal Uloop 1 kHz:	83.3mV
Clamp Open Detection:	not included
Integr. temperature sensor:	not included



## Active Clamp <CMC9>

(TEST-FUCHS part no. 150090371)

Active, small AC and DC current measurement clamp  
Supplied by the <BLRT2> thus batteries are not required

The switch and regulator that are fitted on the clamp are deactivated and have no influence on the operation

Manufacturer:	Fluke modified by TEST-FUCHS
Inner diameter:	20mm (0.8in)
Length:	180mm (7.1in)
Width of the clamp:	15mm (0.6in)
Width of the clamp housing:	25mm (1.0in)
Height:	70mm (2.8in)
Weight:	326g (0.7lb)
Cable length:	4m (157.5in)
Proportion:	10mV/A AC and DC
Max. current measurement:	10A





## Kelvin Probes With Extended Tips Injection <PKL552-2>

(TEST-FUCHS part no. 103240488)

Hardened and spring-loaded Kelvin tips were developed by TEST-FUCHS

Design of these tips ensures their capability to test through varnished and anodized material

The tips are made of hardened steel and can be exchanged

The cable is designed for one current injection and one voltage metering

The plug has to be connected to the plug "INJECTION" of the <BLRT2>

The cable length is 4m (157.5in)



## Kelvin Probes With Extended Tips Current 1 <PKL552-3>

(TEST-FUCHS part no. 103240489)

Hardened and spring-loaded Kelvin tips were developed by TEST-FUCHS

Design of these tips ensures their capability to test through varnished and anodized material

The tips are made of hardened steel and can be exchanged

The cable is designed for one current injection and one voltage metering

The plug has to be connected to the plug "CURRENT 1" of the <BLRT2>

The cable length is 4m (157.5in)



## Kelvin Probes With Standard Tips Injection <PKL552-4>

(TEST-FUCHS part no. 103240490)

### Standard Kelvin tips

Kelvin tips are required for injecting current and for voltage metering

The cable is designed for one current injection and one voltage metering

The plug has to be connected to the plug "INJECTION" of the <BLRT2>

The cable length is 4m (157.5in)



## Kelvin Probes With Standard Tips Current 1 <PKL552-5>

(TEST-FUCHS part no. 103240491)

### Standard Kelvin tips

Kelvin tips are required for injecting current and for voltage metering

The cable is designed for one current injection and one voltage metering

The plug has to be connected to the plug "CURRENT 1" of the <BLRT2>

The cable length is 4m (157.5in)



## Voltage Probes With Extended Tips <PKL552-6>

(TEST-FUCHS part no. 103240502)

Two point voltage metering tips with hardened tips  
 Hardened tips were developed by TEST-FUCHS  
 Design of these tips ensures their capability to break through varnished and anodized material  
 The tips are made of hardened steel and can be exchanged  
 While using this cable, there is no need of any other voltage metering  
 The plug has to be connected to the plug "VOLTAGE" of the <BLRT2>  
 The cable length is 4m (157.5in)



## Injection Probes With Banana Plug And Clips <PKL552-8>

(TEST-FUCHS part no. 103240517)

This cable is used if the test current is fed separately into the measuring point  
 The tips can be chosen. In the scope of delivery there are two measuring tips and two crocodile clips  
 Instead of the delivered measuring tips also other tips can be used if they are approved for 10A test current for three seconds  
 The cable length is 2m (78.7in)



FURTHER VERSIONS, OPTIONAL VERSIONS OR OTHER CABLE LENGTHS ARE AVAILABLE ON REQUEST.

>BLRT2<

# Bonding And Loop Resistance Tester For A350

## >ESNBLRT2KIT<

>ESNBLRT2KIT<

(TEST-FUCHS Art.-No. 150021129)



AIRBUS CERTIFIED

The equipment is developed as multifunctional bonding tester for AIRBUS A350, ATA Chapter 24 and 51.

The following options are realized for this type:

- High Current / Low Frequency Micro-Ohmmeter (Option E)
- Loop Resistance Test (Option N)
- Single Clamp Measurement (Option Y)

- > The tester is housed in a light and practical case with handle for easy handling
- > The high capacity accumulator ensures that the equipment can be used for long periods of time
- > A wide range of accessories is offered according to the list on the following page

>ESNBLRT2KIT<

## SCOPE OF DELIVERY

<p><b>&gt; Basic device</b></p> <p><b>BLRT2</b> (TEST-FUCHS Art-No. 151020031)</p>	<p><b>&gt; Additional accessories</b></p> <p><b>Small Current Injection Clamp for Single Clamp and Clamp-Open Detection and Temperature Sensor &lt;CIC5&gt;</b> (TEST-FUCHS Art-No. 151020059)</p> <p><b>Big Current Injection Clamp for Single Clamp and Clamp-Open Detection and Temperature Sensor &lt;CIC8&gt;</b> (TEST-FUCHS Art-No. 150020835)</p> <p><b>Voltage Probes with Extended Tips &lt;PKL552-6&gt;</b> (TEST-FUCHS Art-No. 103240502)</p> <p><b>Storage Case “EXPLORER 8.850-W“</b> (TEST-FUCHS Art-No. 150090174)</p> <p><b>Standard Battery Charger</b> (TEST-FUCHS Art-No. 103230267)</p> <p><b>Battery Package</b> <b>(2 pcs Accu “SWIT S-307149“)</b> (TEST-FUCHS Art-No. 106220138)</p> <p><b>Self Test Unit</b> (TEST-FUCHS Art-No. 106361013)</p>
<p><b>&gt; Standard scope of delivery</b></p> <p><b>Battery Package</b> <b>(2 pcs Accu “SWIT S-307149“)</b> (TEST-FUCHS Art-No. 106220138)</p> <p><b>Power Supply Unit “S307164“</b> (TEST-FUCHS Art-No. 103070582)</p> <p><b>Shoulder Strap Type “1472“</b> (TEST-FUCHS Art-No. 106330923)</p> <p><b>Connecting Cable Mini USB B-A 2m</b> (TEST-FUCHS Art-No. 106331470)</p>	<p><b>&gt; Dimensions and weight</b></p> <p>Length: 680mm (26.8in) Width: 530mm (20.1in) Height: 270mm (10.6in) Weight: 19.1kg (42.1lb)</p>
<p><b>&gt; Options</b></p> <p><b>High Current / Low Frequency Micro-Ohmmeter (Option E)</b> (TEST-FUCHS Art-No. 151020038)</p> <p><b>Loop Resistance Test (Option N)</b> (TEST-FUCHS Art-No. 151020041)</p> <p><b>Single Clamp Measurement (Option Y)</b> (TEST-FUCHS Art-No. 151020045)</p>	

**An exact description of the accessories and the options can be taken of the product portfolio of the “Bonding and Loop Resistance Tester >BLRT2-XX-X<“.**

## Bonding And Loop Resistance Tester

### >BLRT3<



The equipment is developed as multifunctional bonding tester. It is especially used in aircraft manufacturing. It can be used on all aircraft types.

It is capable of performing various tests depending on used accessories.

The test capability ranges from manual 4-wire-bonding tests and loop resistance tests with current clamps up to the possibility to carry out these tests automatically and to store the measuring values directly in the database.

- > All measuring functions can be selected and combined independently and can also be retrofitted at a later stage
- > The <BLRT3> is housed in a light and practical case ensuring easy transport for the user
- > Long testing period by hot-swap capable Li-Ion batteries
- > A wide range of accessories is available for this tester



## GENERAL INFORMATION

- > Large touch display for good readability and integrated Windows PC
- > Software enables simple and intuitive operation
- > Multi-function tester with selectable standard and special functions
- > Coded pincers and test cables can be replaced independently from the device
- > USB, LAN and optional WLAN interface
- > Automatic test procedures with adaptable interface (e.g.: Excel)
- > App available for BLRT3 remote control
- > Including self test unit for function control of the test equipment and the measuring clamps
- > A customer specific automatic test enables an easy implementation of existing processes

## TECHNICAL DATA - TEST EQUIPMENT

<p>&gt; <b>Electrical supply (requirements):</b></p> <p>Mains charger adapter: 1/N/PE AC 50/60Hz                  Accumulator: 2x Li-Ion 14.4V 72Wh</p>	<p>&gt; <b>Interface:</b></p> <p>Interface: 1x LAN (RJ45)                  2x USB2.0 (USB-A)                  WLAN</p> <p>Memory capacity: &gt; 1000 measuring values</p>
<p>&gt; <b>Functions:</b></p> <p>Measuring functions: see "FUNCTIONS"                  Ranges: see "OPTIONS"                  Accuracy: see "OPTIONS"</p>	<p>&gt; <b>Operating conditions (operation):</b></p> <p>Temperature: 10°C to 40°C (50°F to +104°F)                  Rel. humidity: max. 95% relative humidity                  (non-condensing)</p>
<p>&gt; <b>Output values:</b></p> <p>Output voltage DC: max. 24VDC                  Output current DC: max. 10ADC                  Output voltage AC: max. 55VAC                  Output power AC: max. 45W</p>	<p>&gt; <b>Operating conditions (storage):</b></p> <p>Temperature: -20°C to +70°C (-4°F to 158°F)                  Air humidity: max. 95% relative humidity                  (non-condensing)</p>
<p>&gt; <b>Measurement range:</b></p> <p>Functions: Measurement ranges and tolerances are listed in the item "OPTIONS"</p> <p>Battery voltage: Range: 0 to 28V                  Tolerance: 0.5% of reading</p>	<p>&gt; <b>Dimensions and weight:</b></p> <p>Width: 320mm (12.6in)                  Depth: 100mm (4.3in)                  Height: 220mm (9.1in)                  Weight: approx. 4 kg (8.8lb)</p>

## MEASURING FUNCTIONS

**BONDING TESTER (OPTION A)**

(TEST-FUCHS part no. 159060107)

**> Technical description**

Bonding Tester with 10A, 1A and 0.1A test current. It works as a Kelvin Resistance Meter.

The bonding tester measures the resistive connection between two measuring points.

During the bonding test an increased test current is injected in the unit under test by means of test probes or terminals. The voltage drop is recorded on two test points. The contact resistance between voltage test points is calculated by means of current and voltage values.

This measuring method only works when the total measurement current flows through the unit under test.

Schematic diagram of the test set-up

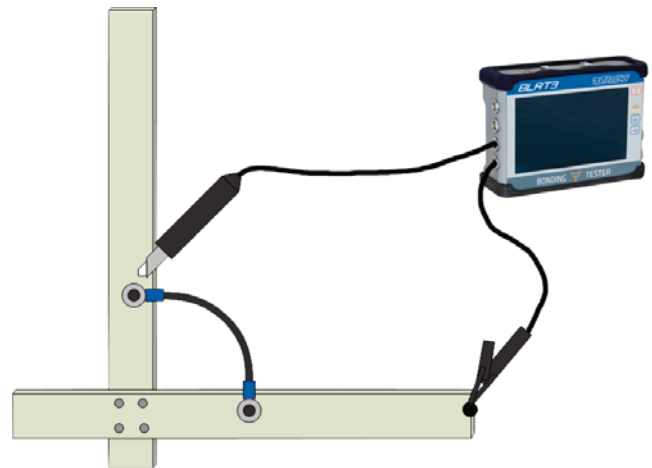
**LOOP RESISTANCE TESTER (OPTION B)**

(TEST-FUCHS part no. 159060108 for option B - 1.000Hz)

**> Technical description**

The "Loop Resistance Test" measures the overall resistance of a bonding loop. It is used for example when a metal tube has multiple connections to structure.

A "Smart Current Injection Clamp" (SCIC) injects alternating current into the current loop. The voltage required therefore is measured. A "Smart Current Measurement Clamp" (SCMC) measures the injected current. Alternatively, a combined "Smart Current Injection and Measurement Clamp" (SCIMC) can be used. The overall resistance of the current loop is calculated by means of voltage and current value.

For this method it is essential that there is only one current loop.

Schematic diagram of the test set-up

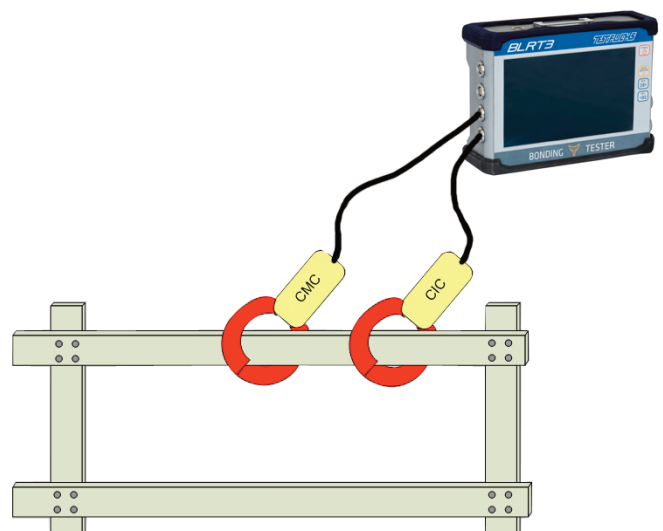

TECHNICAL DATA - MEASURING FUNCTIONS

Measuring function	Option	TEST-FUCHS part no.	Measuring range (mOhm)	Resolution (µOhm)	Adjust current (A)	Frequency (Hz)	Standard accuracy (% o.m.v.)	Required accessories	Remarks
Bonding Tester	<b>A</b>	159060107	2 to 1000 at 0.1A	1	0,1 1 10	DC	0.2% m.v. +0.2% f.s.	2 x Kelvin Probe	Standard Bonding Test
Loop Resistance Tester 1000Hz	<b>B</b>	159060108	1 to 400	10	1	1000	5% m.v. or 2mOhm	1 x Current Injection Clamp 1 x Current Measurement Clamp or 1 x Combined Injection Measurement Clamp	Standard Loop Resistance Test

## Standard Accessories For Bonding And Loop Resistance Tester

### >BLRT3<

#### Battery

##### (2 batteries PH3054HD)

(TEST-FUCHS part no. 106220238)

Manufacturer:	INSPIRED ENERGY
Type:	PH3054HD
Output voltage:	14,4V
Power:	72Wh
Current output:	20A
Intermediate charging is possible (no memory effect)	



#### Desktop Charger

(TEST-FUCHS part no. 106220260)

Manufacturer:	INSPIRED ENERGY
Model:	PH1000
Input:	AC 100 to 240V; 50 / 60Hz
Output:	DC 10 to 17V; 1.8A
Loading time:	approx. 3h



#### Shoulder Strap

##### Type "1472"

(TEST-FUCHS part no. 106330923)



### Self Test Unit Loop Resistance

(TEST-FUCHS part no. 106375848)

- L1673-16/000/000 100mOhm
- not calibrated



### Self Test Unit Loop Resistance

(TEST-FUCHS part no. 106375838)

- L1673-6/000/000 10mOhm
- not calibrated



### Self Test Unit Bonding

(TEST-FUCHS part no. 106172198)

- BURSTER 10mOhm
- not calibrated



### Skross Travel Adapter

(TEST-FUCHS part no. 103206789)



## Optional Accessories For Bonding And Loop Resistance Tester

### >BLRT3<

#### Storage Case “EXPLORER 8.850-W“ (TEST-FUCHS part no. 107102170)

With wheels and extendable handle  
Very solid and stackable  
Coated inside with foam  
Compartments for: - BONDING AND LOOP RESISTANCE  
TESTER <BLRT3>  
- Various accessories  
- Technical documentation

Dimensions: 670 x 510 x 372mm  
(26.0 x 20.1 x 14.6in)

Weight (empty): 12kg (26.5lb)



Symbolic figure

#### Desktop Charger (TEST-FUCHS part no. 106220239)

Manufacturer: Inspired Energy  
Type: PH5000  
Input: AC 100 to 240V; 50 / 60Hz  
Output: DC 10 to 17V; 1.8A  
Loading time: approx. 3h





### Small Smart Current Injection Clamp <SCIC1>

(TEST-FUCHS part no. 150021371)

Manufacturer:	Fluke modified by TEST-FUCHS
Inner diameter:	21mm (0.8in)
Length:	135mm (5.3in)
Width of the clamp:	18mm (0.7in)
Width of the clamp housing:	28mm (1.1in)
Height:	48mm (1.9in)
Weight:	494g (1.1lb)
Cable length:	4m (157.5in)
Windings, primary:	1000
Windings, measurement:	10
Supply max. 1000Hz:	55V
Uloop max. 1kHz:	55mV



### Small Current Measurement Clamp <SCMC1>

(TEST-FUCHS part no. 150021373)

Manufacturer:	Fluke modified by TEST-FUCHS
Inner diameter:	21mm (0.8in)
Length:	135mm (5.3in)
Width of the clamp:	18mm (0.7in)
Width of the clamp housing:	28mm (1.1in)
Height:	48mm (1.9in)
Weight:	494g (1.1lb)
Cable length:	4m (157.5in)
Windings, primary:	1,000
Max. current measurement:	10A



## Small Smart Current Injection and Measurement Clamp <SCIMC1> (TEST-FUCHS part no. 150021375)

Manufacturer:	TEST-FUCHS
Inner diameter:	26mm (1.0in)
Length:	175mm (6.9in)
Width of the clamp:	31mm (1.2in)
Width of the clamp housing:	31mm (1.2in)
Height:	62mm (2.4in)
Height of the clamp arm:	16mm (0.6in)
Cable length:	3m (118.1in)
Windings, primary:	600
Winding, secondary	
- Voltage measurement:	60
- Current measurement:	600
Maximal supply 1 kHz:	30V
Maximal Uloop 1 kHz:	50mV



### Big Smart Current Injection Clamp <SCIC2>

(TEST-FUCHS part no. 150021372)

Manufacturer:	Fluke modified by TEST-FUCHS
Inner diameter:	55mm (2.2in)
Length:	230mm (9.1in)
Width of the clamp housing:	40mm (1.6in)
Height:	106mm (4.2in)
Weight:	1.6kg (3.5lb)
Cable length:	4m (157.5in)
Windings, primary:	95
Windings, measurement:	10
Supply max. 1000Hz:	8V
Uloop max. 1kHz:	80mV



### Big Current Measurement Clamp <SCMC2>

(TEST-FUCHS part no. 150021374)

Manufacturer:	Fluke modified by TEST-FUCHS
Inner diameter:	55mm (2.2in)
Length:	230mm (9.1in)
Width of the clamp housing:	40mm (1.6in)
Height:	106mm (4.2in)
Weight:	1.6kg (3.5lb)
Cable length:	4m (157.5in)
Windings, primary:	1,000
Max. current measurement:	10A



**Big Smart Current Injection and Measurement Clamp <SCIMC2>**  
(TEST-FUCHS part no. 150021376)

Manufacturer:	TEST-FUCHS
Inner diameter:	66mm (2.6in)
Length:	190mm (7.5in)
Width of the clamp housing:	40mm (1.6in)
Height:	190mm (7.5in)
Cable length:	3m (118.1in)
Windings, primary:	600
Winding, secondary	
- Voltage measurement:	60
- Current measurement:	600
Maximal supply 1 kHz:	40V
Maximal Uloop 1 kHz:	65mV



**Measuring line A****<PKL574-1>**

(TEST-FUCHS part no. 103241977)



Figure of a similar measuring line

The measuring line is provided for the earth connection to the UUT. Respectively one current and one voltage pin is fixed to the structure.

This measuring line consists of a plug with bayonet coupling and a 5m (196.8in) long cable.

The 2 safety banana connectors form the ending.

All standard-pressure peaks with 4mm (0.2in) connection and an admissible current rating of 10A can be used.

- > Conducting lines: 1 (A)
- > Measuring lines: 1 ( $A_{\text{sense}}$ )
- > Complete 4-conductors-measurement possible: Yes with measuring line B
- > Complete 2-conductors-measurement possible: No
- > Current rating: max. 10A
- > Connecting cable: 5,000mm (196.8in)
- > Accessories: Cable bag >KABTA2<

## Measuring line B

<PKL574-2>

(TEST-FUCHS part no. 103241978)



Figure of a similar measuring line

The measuring line is provided for the earth connection test (measuring line B) in combination with measuring line A.

This measuring line consists of a live line (B) and a measuring line (B<sub>sense</sub>).

This measuring line consists of a plug with bayonet coupling and a 5m (196.8in) long cable.

The 2 safety banana connectors form the ending.

All standard-pressure peaks with 4mm (0.2in) connection and an admissible current rating of 10A can be used.

- > Conducting lines: 1 (B)
- > Measuring lines: 1 (B<sub>sense</sub>)
- > Complete 4-conductors-measurement possible: Yes with measuring line A
- > Complete 2-conductors-measurement possible: No
- > Current rating: max. 10A
- > Connecting cable: 5,000mm (196.8in)
- > Accessories: Cable bag >KABTA2<

FURTHER VERSIONS, OPTIONAL VERSIONS OR OTHER CABLE LENGTHS ARE AVAILABLE ON REQUEST.

>BLRT3<

# A400M Tools

TAN	P/N	AGE Number	NSN	Description	CE	Series / development
150030028	98M24008074000	AJA24243074000	1730-41-002-6025	Safety Pin RAT	X	series
150030158	98M24008078000	AJA24003078000	1730-41-002-6024	RAT Lifting Device	✓	series
150030029	98M24248063000	AJA24243063000	1730-41-002-2531	Device R/I RAT	✓	series
150030030	98M24248084000	AJA24243084000	1730-41-002-2421	RAT Door Fixing Device	X	series
150030032	98M24248085000	AJA24243085000	4920-41-002-2420	Safety Cage RAT Test	X	series
150030036	98M27508060000	AJA27503060000	1730-41-002-2452	Rigging Tool Set	X	series
150030037	98M27508061000	AJA27503061000	1730-41-002-2447	STL Locking Adapter	X	series
150030038	98M27508107000	AJA27503107000	1730-41-002-2408	Stand Support Out-/Inboard Flap	X	series
150030039	98M27518089000	AJA27513089000	1730-41-002-2407	Stand Support Fairing	X	series
150030040	98M27508009000	AJA27543009000	5120-41-002-5196	Wing Tip Brake (WTB) Flap Maintenance Tool	X	series
150030045	98M29008111000	AJA29003111000	1730-41-002-2557	Hand Pump for CD Ramp Actuator	X	series
150030046	98M55308005000	AJA55303005000	1730-41-002-2526	Extractor VTP Attachment Bolts	✓	series
150030047	98M27508083000	AJA27503083000	4920-41-002-2416	BSA Locking Tool	X	series
150030054	98M47008700000	AJA47008700000	1730-41-002-2547	Sling-R/I, PROBIGGS	✓	series
150030055	98M47008703000	AJA47008703000	4920-41-002-2546	Tool Set Installation PROBIGGS	X	series
150030057	98M21503126000	AJA21503126000	1730-41-002-2533	Stand Support ACM HEX Plenum	X	series
150030053	98M57578442000	AJA57573442000	5120-41-002-4229	Extractor FWD Support-Beam Bolts	X	series
150030135	98M27408448000	AJA27403448000	1730-41-002-2548	Cap-Prot, THSA-Bearing	X	series
150030034	98M27208004000	AJA27203004000	1730-41-002-2554	Turn Barrel, Rudder	✓	series
150030035	98M27208044000	AJA27203044000	1730-41-002-2552	Stand Support Rudder Actuator	✓	series
150030033	98M27208002000	AJA27203002000	1730-41-002-2584	Device - R/I, Rudder Actuator	✓	series
150030041	98M55308024000	AJA55303024000	1730-41-002-2453	Sling, R/I VTP	✓	series
150030042	98M55308047000	AJA55303047000	1730-41-002-2419	Stand Support, VTP	X	series
150030043	98M55368018000	AJA55363018000	4920-41-002-2417	Device, VTP Bolt-Centering	X	series
150030130	98M24248445000	AJA24243445000	1730-41-002-2418	Cover RAT	X	series
150030129	98M25008444000	AJA25003444000	1730-41-002-3902	Protection Cover Bilge	X	series
150030128	98M47158706000	AJA47158706000	1730-41-002-2587	Cover OBIGGS Outlet	X	series
150030121	98M21008704000	AJA21008704000	1730-41-002-2579	Cover OBIGGS Air Inlet LH	X	series
150030122	98M21008705000	AJA21008705000	1730-41-002-2534	Cover OBIGGS Air Outlet LH	X	series
150030115	98M21008031000	AJA21003031000	1730-41-002-2529	Cover ECS Air Outlet LH	X	series
150030116	98M21008033000	AJA21003033000	1730-41-002-2448	Cover ECS Air Outlet RH	X	series
150030117	98M21008034000	AJA21003034000	1730-41-002-2422	Cover LH UBV Air Inlet	X	series
150030118	98M21008035000	AJA21003035000	1730-41-002-2415	Cover RH UBV Air Inlet	X	series
150030119	98M21008036000	AJA21003036000	1730-41-002-2577	Cover OBOGS AIR Inlet RH	X	series
150030120	98M21008037000	AJA21003037000	1730-41-002-2585	Cover OBOGS AIR Outlet RH	X	series
150030131	98M21008066000	AJA21003066000	1730-41-002-2576	Cover UBV Air Outlet	X	series
150030123	98M49008068000	AJA49003068000	1730-41-002-2536	Cover APU Exhaust	X	series
150030124	98M49008069000	AJA49003069000	1730-41-002-2535	Cover Air Intake APU	X	series
150030125	98M49008070000	AJA49003070000	1730-41-002-2532	Cover Vent Grid APU RH	X	series
150030126	98M49008071000	AJA49003071000	1730-41-002-2530	Cover Vent Grid APU on Top	X	series
150090237	M10TC0012002	AJE10104256000	1730-41-002-7008	Engine Ground Covers Kit	X	series
150090267	M10TC0012002-M1	AJE10104256000	TBD	Engine Ground Covers Kit (-M1)	X	series
150020711	NWAT1	AJE32514180000	4920-41-002-7358	Nose Wheel Alignment Tool	X	development
150030150	EFESTT1	AJE26214374000	4920-41-002-3466	Engine Fire Exting System Test Tool	X	series
150020713	WCS1	AJE32104529000	1680-41-002-5390	Weight on Wheel Condition Simulator	X	series
150090212	DRICD1	TBD	TBD	Device for R/I Cargo Door	✓	series
150090265	HFK1	AJA29003453000	TBD	KIT FLUSH, HYD HDU	X	development
150030204	RTI400M	AJE24244895000	TBD	RAT GTT Hydraulic Service	✓	series



safety in test > safety in flight



# AIRBUS A400M

## Test Equipment

### STTE



Special Tools



Safety Devices



Devices for Installing and Reinstalling



Lifting Devices



Covers



Safety Pins

### SSE



Mobile Air Conditioner  
>BKG6D<



Oxygen and Nitrogen Trolley  
>ONT1<



RAT GTT Hydraulic Service  
>RT400M<



Hydraulic Ground Power Unit Diesel Motor Driven  
>HST210SKA<



Hydraulic Ground Power Unit Electrically Driven  
>HST21ESKA<

### Test Equipment



Bleeding Tool Set  
>BT51<



Impedance Measuring Equipment for Loop Resistance  
>IM2-FS<



Bonding and Loop Resistance Tester  
>BLRT3<



Weight on Wheel Condition Simulator  
>WCST<



Electrical Module for Cargo Door and Ramp Operation  
>MCDRT<



Loop Through Trolleys for MHPA400M  
>MHPA400M<

### Test Equipment



Particle Count Trolleys for MHPA400M  
>MHPA400M<



Test System for Cargo Hold and Tunable Vibration Absorber System  
>TS-CH-TVAS1<



Engine Fire Extinguishing System Test Tool  
>EFESTT1<



Bonding Tester  
>MWP0L-24FS<



Hydraulic Simulation for Iron Bird  
>GTFB400M<



Hydraulic Pump Loading System  
>HPL5400<

### Test Equipment



Mobile Hydraulic Test System for Fuselage  
>MHPA400M<



Electric and Hydraulic Test Stand for Vertical Tail Tact 5  
>EHP400T5<



Test System for Door Ramp Actuation System  
>TS-DRAS1<



Particle Measuring System  
>PMA400M<



Cable Test Set  
>KPL4<



VFC Cooling System  
>VCS400<

